

## Механизъм за интериорна плъзгаща плътна врата със скрита релса с плавно отваряне и затваряне до 80 кг

# HIDDEN

Цена за комплект за 1 плъзгаща врата с плавно отваряне и затваряне за деб. мин 40 мм

Ширина на вратата до 1 150 мм

Код: 742-1800-1150

Цена: 333,00 лв с ДДС

Ширина на вратата до 1 530 мм

Код: 742-1800-1530N

Цена - 378,00 лв с ДДС

/без дръжка/

линк за монтаж: <https://youtu.be/pp78kl4PKqE>



## KIT 1800-1150 - MAX 80 KG

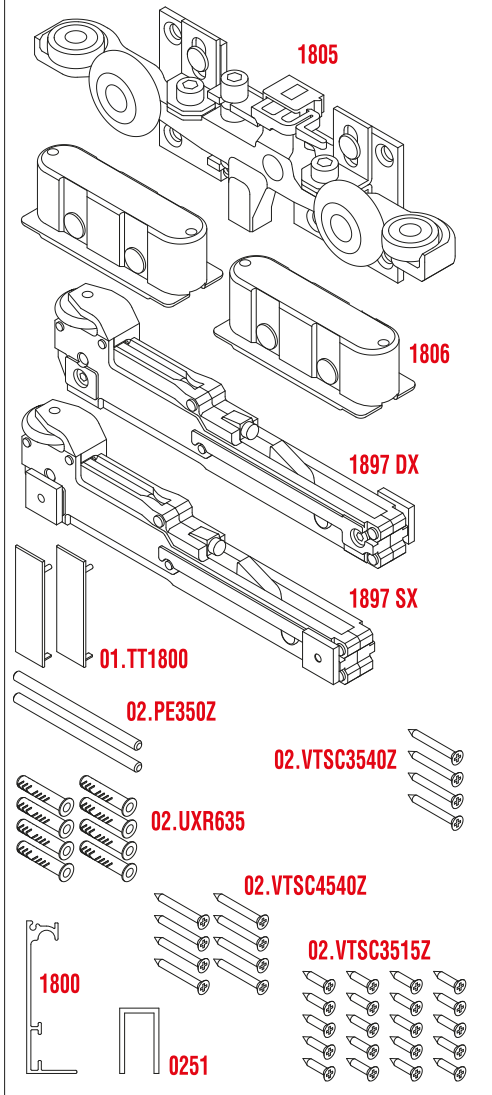

### Legenda KIT / Kit Legend

<b>1805</b>	Guida superiore regolabile Adjustable upper truck
<b>1806</b>	Carrello inferiore Lower truck
<b>0106</b>	Guida inferiore Lower runner
<b>01.TT1800</b>	Tappo terminale End cover
<b>1897</b>	Decelerante Soft Closing Stopper
<b>02.PE350Z</b>	Perno Pin
<b>02.VTSC3540Z</b>	Vite 3.5x40 Screw 3.5x40
<b>02.VTSC4540Z</b>	Vite 4.5x40 Screw 4.5x40
<b>02.UXR635</b>	Tassello Dowel
<b>1800</b>	Profilo superiore Upper profile
<b>0251</b>	Profilo inferiore Lower profile

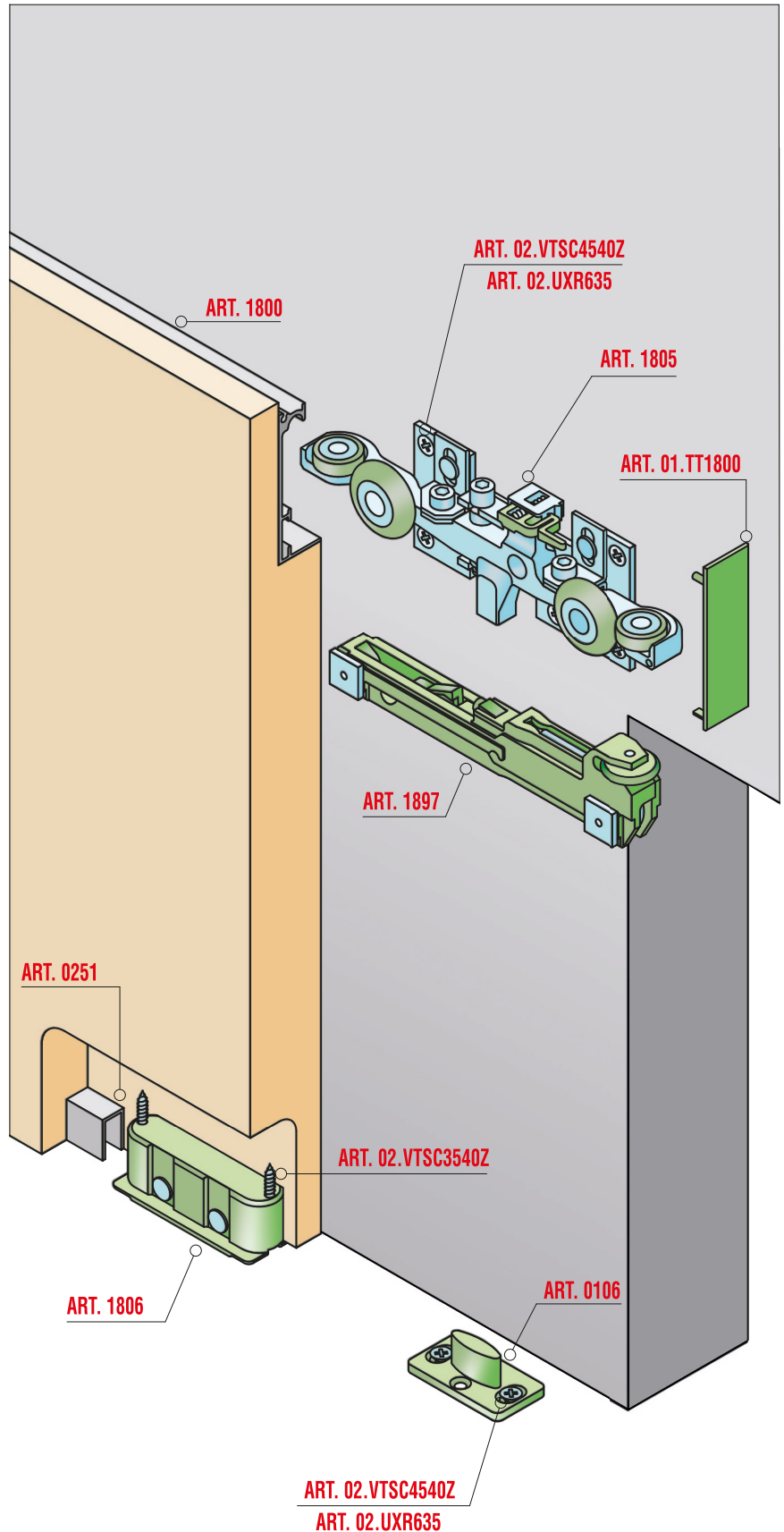

### Sezione verticale senza battiscopa Vertical section without skirting board

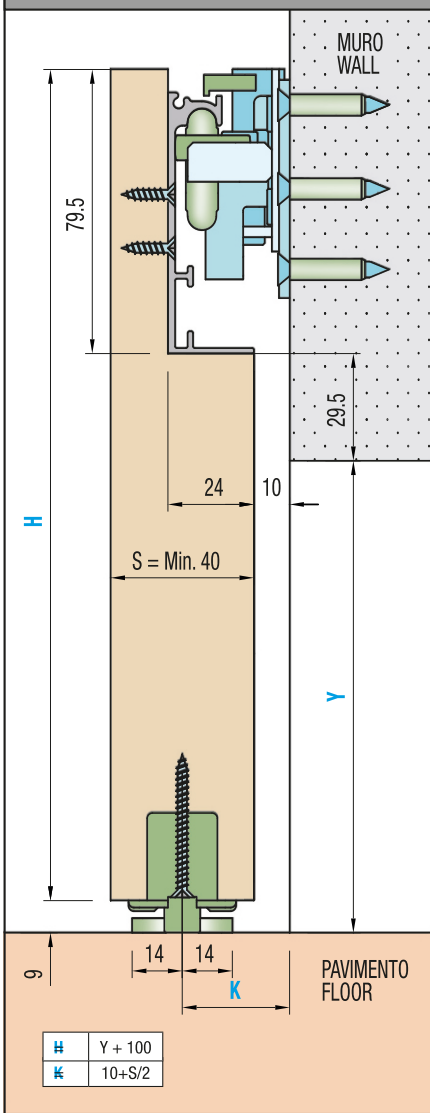

### Sezione verticale con battiscopa Vertical section with skirting board

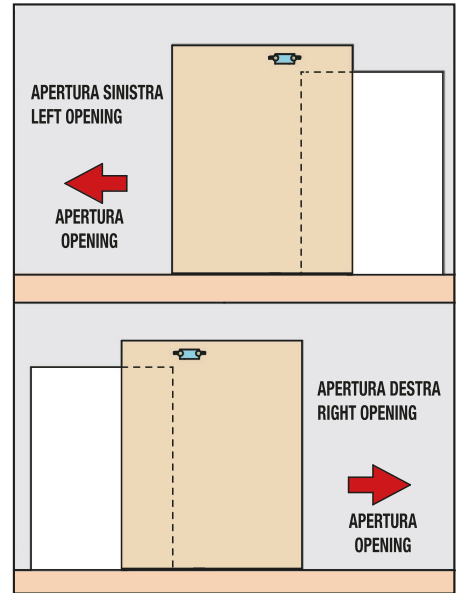
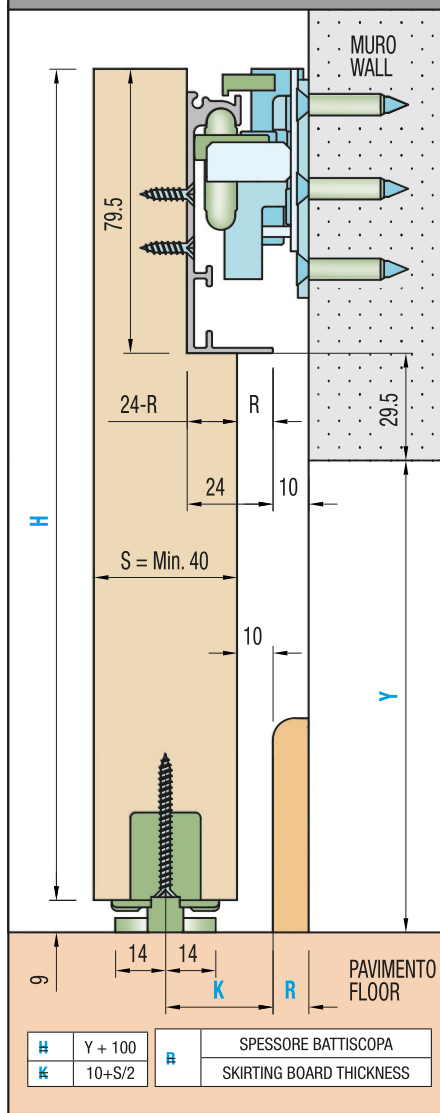

### Posizione guida inferiore Lower guide position

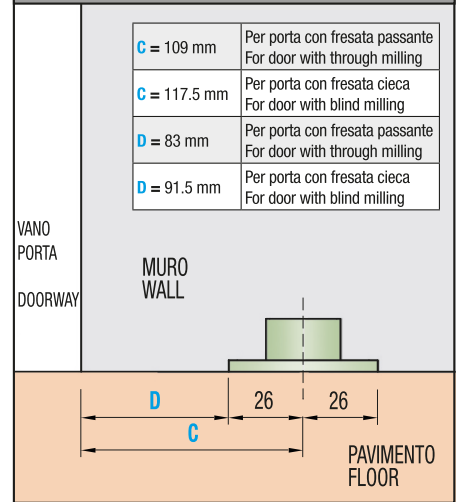

### Posizione guida superiore / Upper truck position

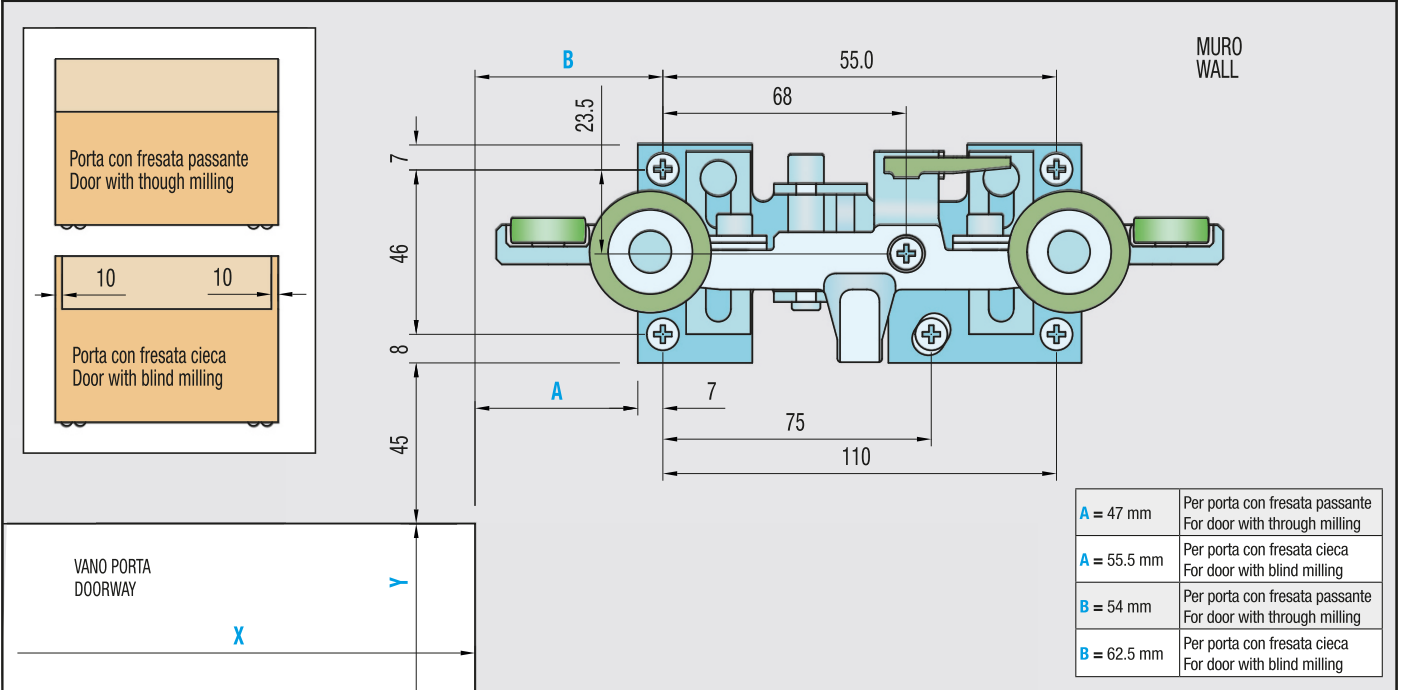

## Dimensioni standard per porta con fresata passante Standard dimensions for door with through milling

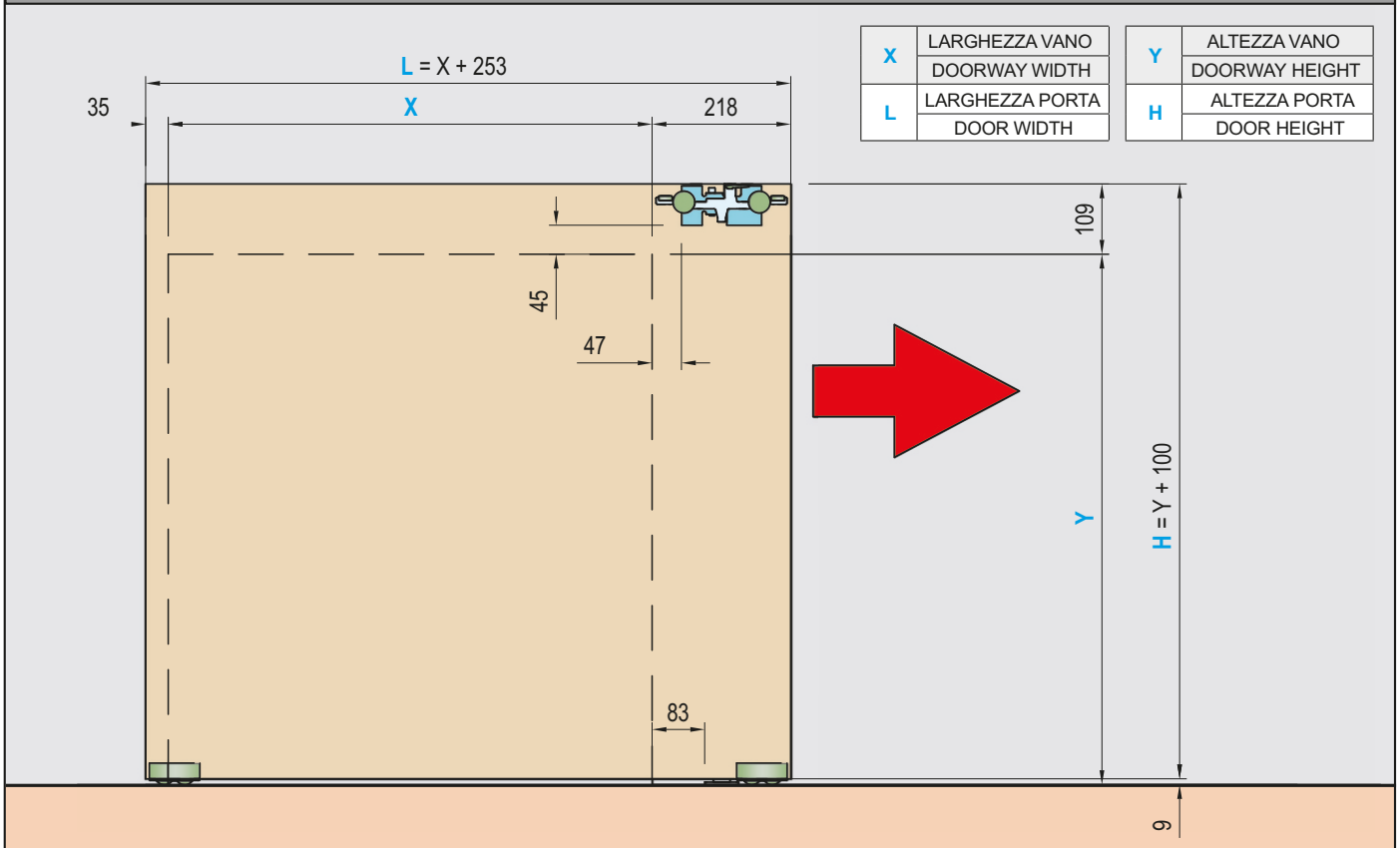

## Dimensioni standard per porta con fresata cieca Standard dimensions for door with blind milling

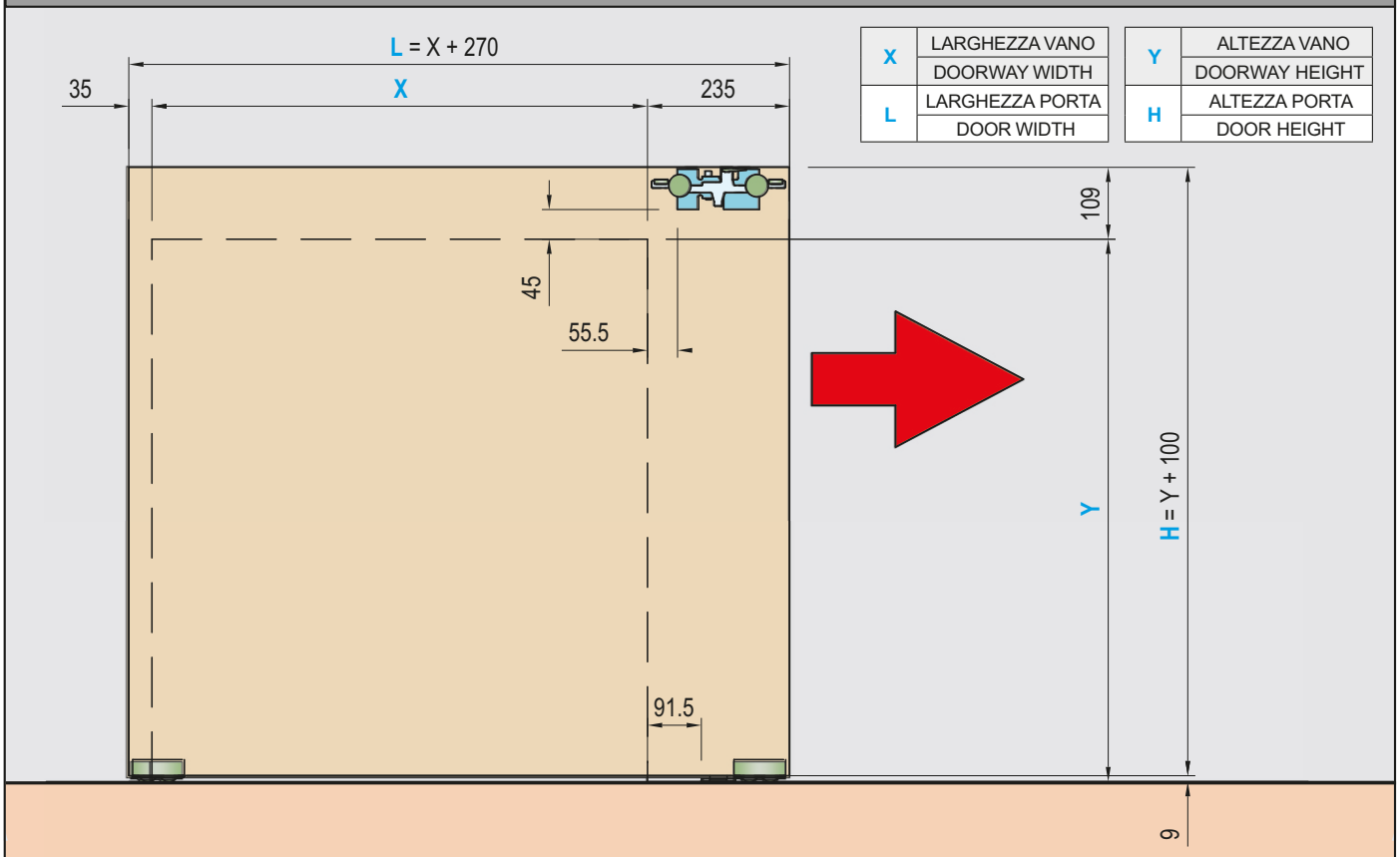



## Schema di foratura per porta con fresata passante Door drilling with through milling

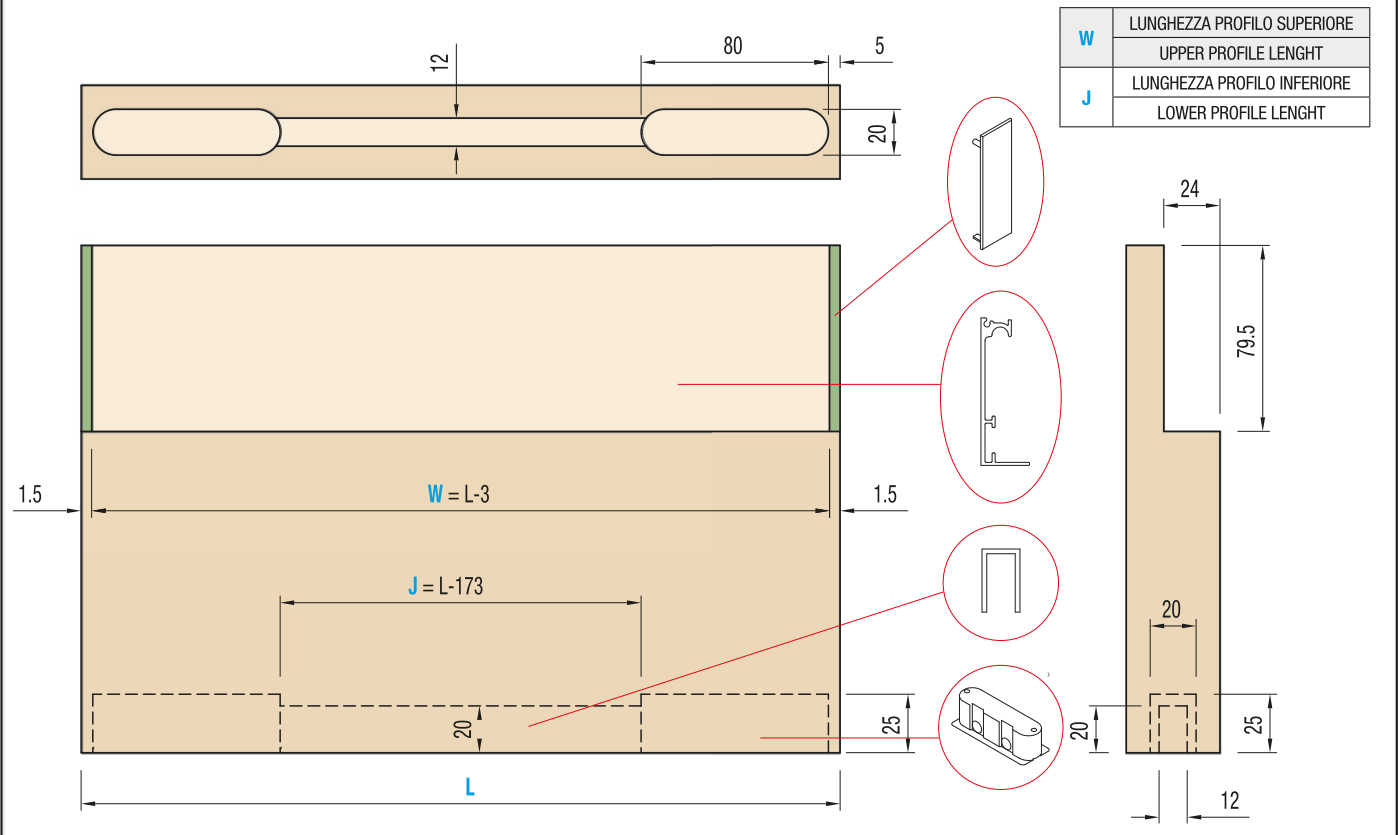

## Schema foratura per porta con fresata cieca Door drilling with blind milling

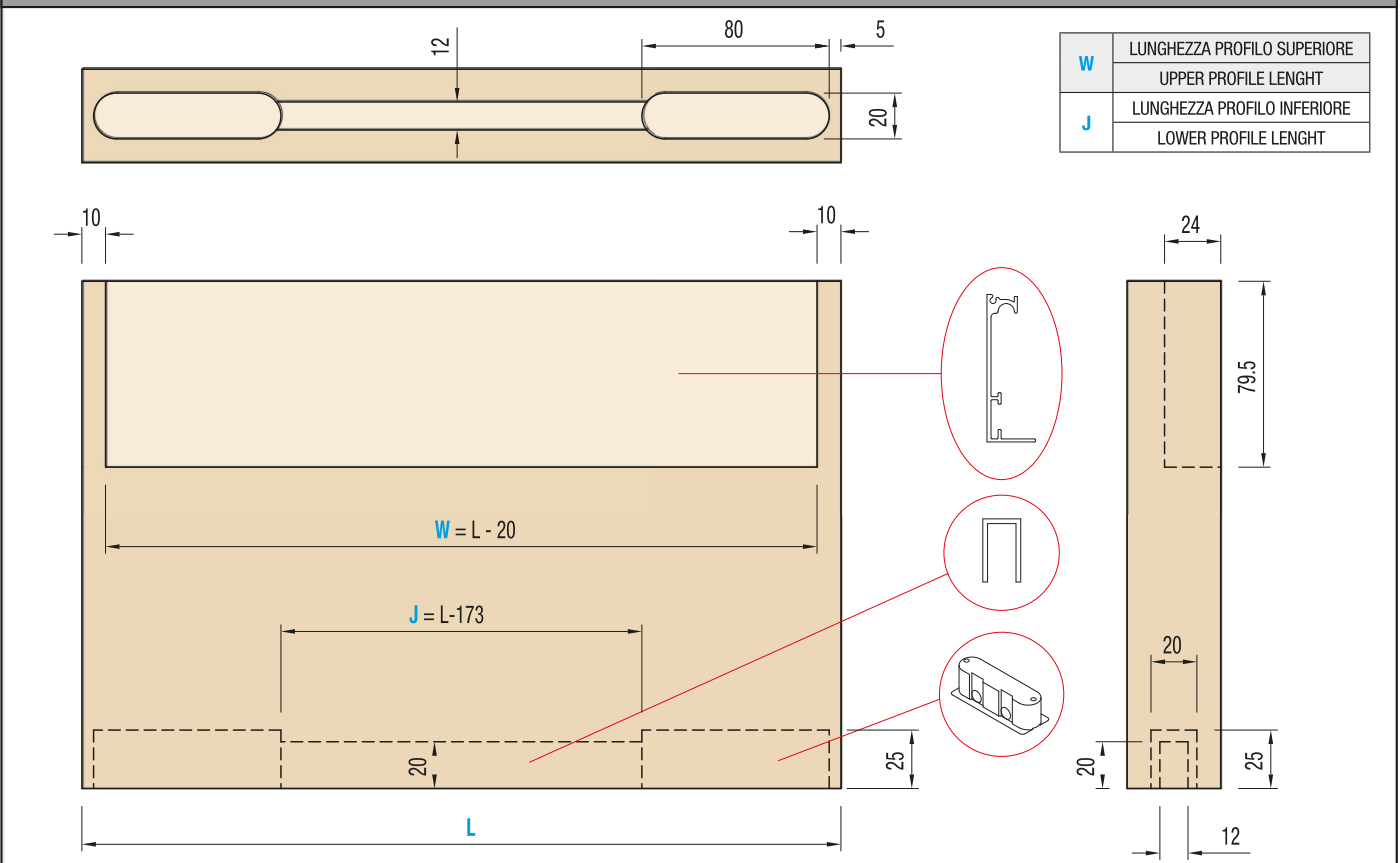

## Dispositivo di riarmo automatico / Automatic self activating device

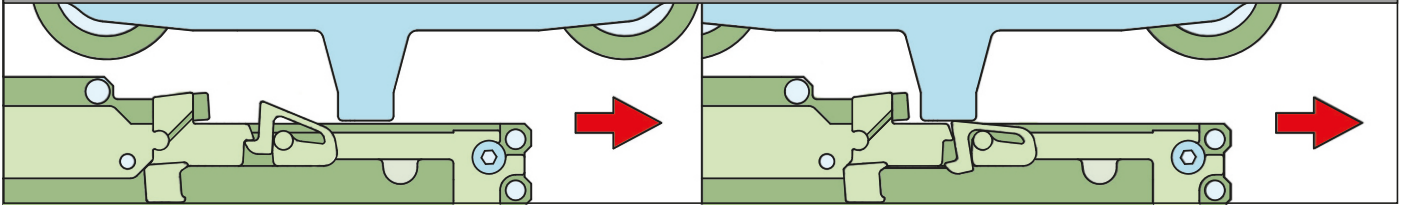

## Istruzioni di montaggio / Assembly instructions

1

Posizionare la mezzeria della porta in corrispondenza della guida fissata a muro. Controllare che l'antiscambiamento non sia attivato come da figure sottostanti. Fit the center line of the door close to the upper truck previously fastened to the wall. Check that the clasp is not triggered, as shown in the figures below.

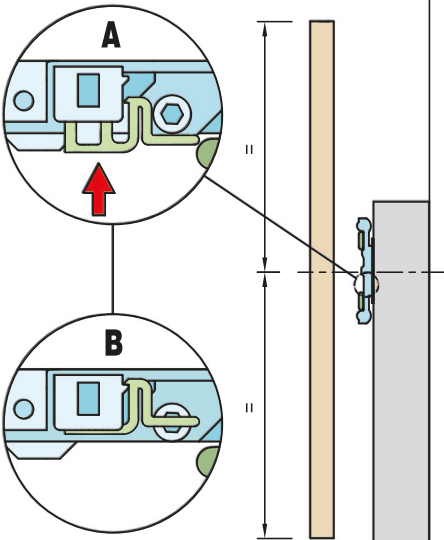

2

Posizionare la porta a cavallo della guida ART. 0106 facendo poggiare a terra le ruote inferiori. Position the door astride the runner ART. 0106 lying the lower wheels on the ground.

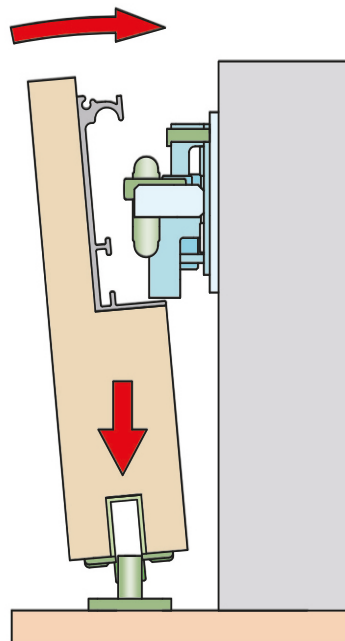

3

Mettere la porta in posizione verticale facendo poggiare il profilo alle ruote della staffa superiore. Mantenere la porta spinta contro la staffa superiore sino a fine montaggio. Put the door in a vertical position, placing its profile on the wheels of the upper truck. Keep the door pushed against the upper truck till the end of the assembly.

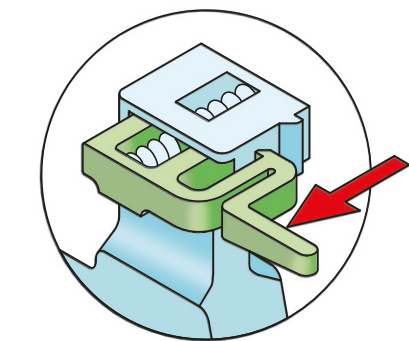
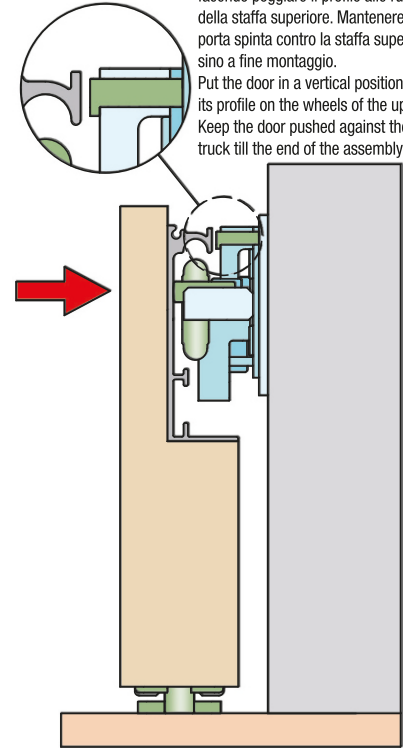

4 Tirare la leva dell'antiscambiamento. Pull the lever of the clasp.

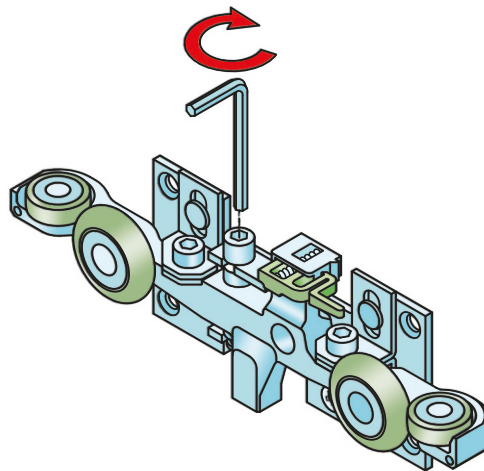

6 Avvitare la vite di regolazione dell'altezza della staffa a parete. Fasten the screw for the adjustment of wall bracket height.

Il bilanciamento sale avvicinando le ruote al profilo. The rocker arm rises, moving the wheels closer to the profile.

Quando l'antiscambiamento emette un sonoro "Click", smettere di avvitare. When the clasp makes a loud "Click", stop fastening.

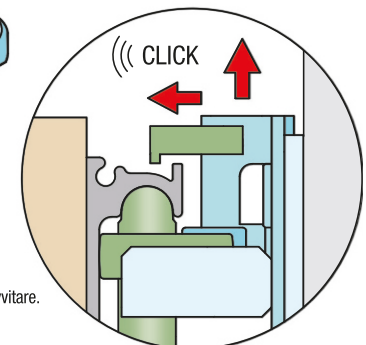
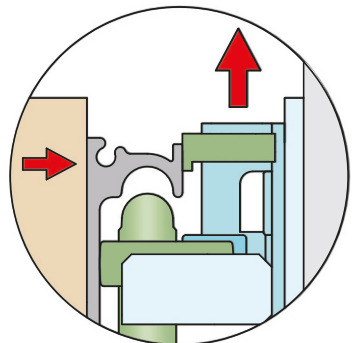

5

L'antiscambiamento va automaticamente in appoggio al profilo superiore. The clasp will automatically lie on the upper profile.

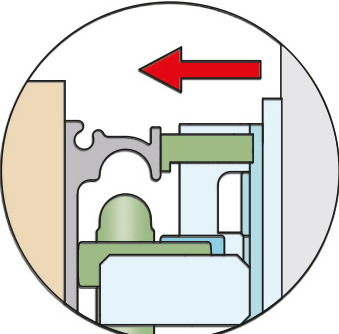

## Regolazione allineamento porta/muro / Door/Wall alignment adjustment

7

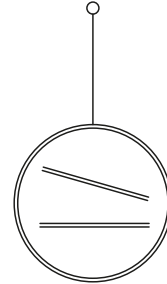
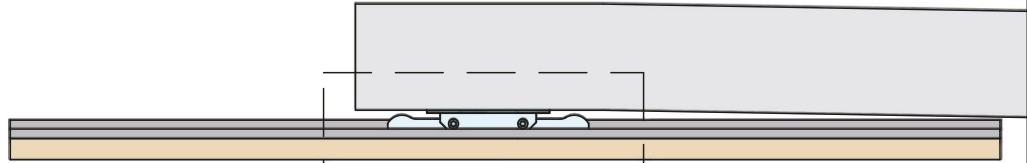
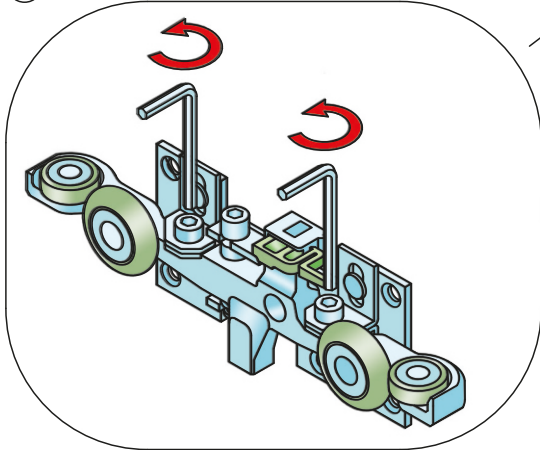

SE LA PORTA NON PARALLELA AL MURO  
SVITARE LE 2 APPOSITE VITI DI BLOCCAGGIO

IF THE DOOR IS NOT ALIGNED WITH THE WALL  
LOOSEN THE FIXING SCREWS

8

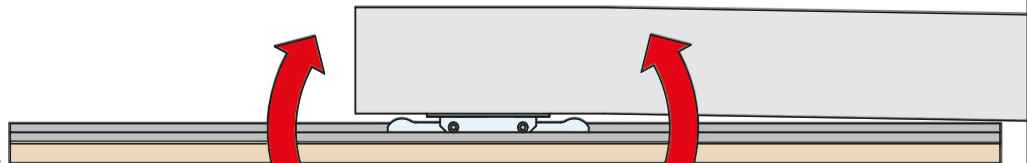
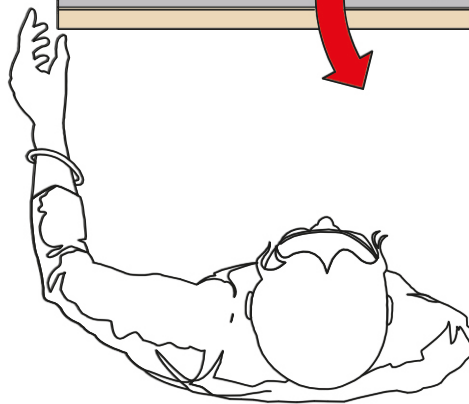

ALLINEARE LA PORTA AL MURO MANUALMENTE  
ALIGN MANUALLY THE DOOR WITH THE WALL

9

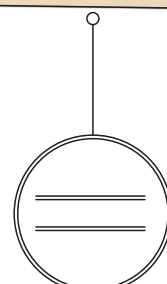
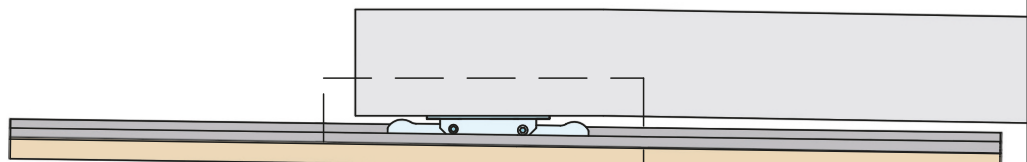
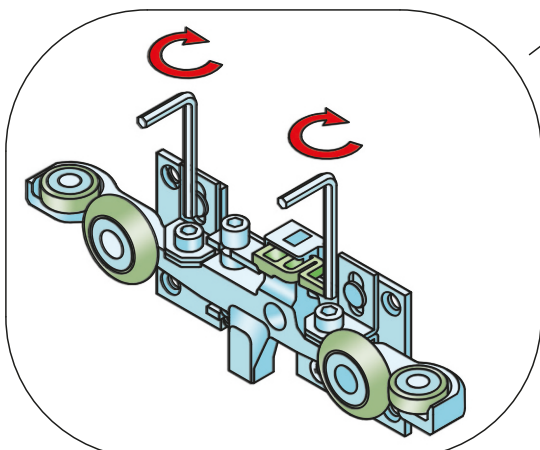

BLOCCARE L'ALLINEAMENTO SERRANDO LE DUE VITI DI FISSAGGIO  
LOCK THE ALIGNMENT SCREWING THE FIXING SCREWS

## Механизъм за интериорна плъзгаща стъклена врата със скрита релса с плавно отваряне и затваряне до 80 кг

# HIDDEN GLASS

Цена за комплект за 1 плъзгаща  
врата с плавно отваряне и  
затваряне за стъкло 8/10/12 мм

Ширина на вратата до 1 150 мм

Код: 742-1800-1150VAC

Цена: 427,00 лв с ДДС

Ширина на вратата до 1 450 мм

Код: 742-1800-1450VAC

Цена - 498,00 лв с ДДС

/без дръжка и стъкло/

линк за монтаж: <https://youtu.be/BVhpyKYgd-k>



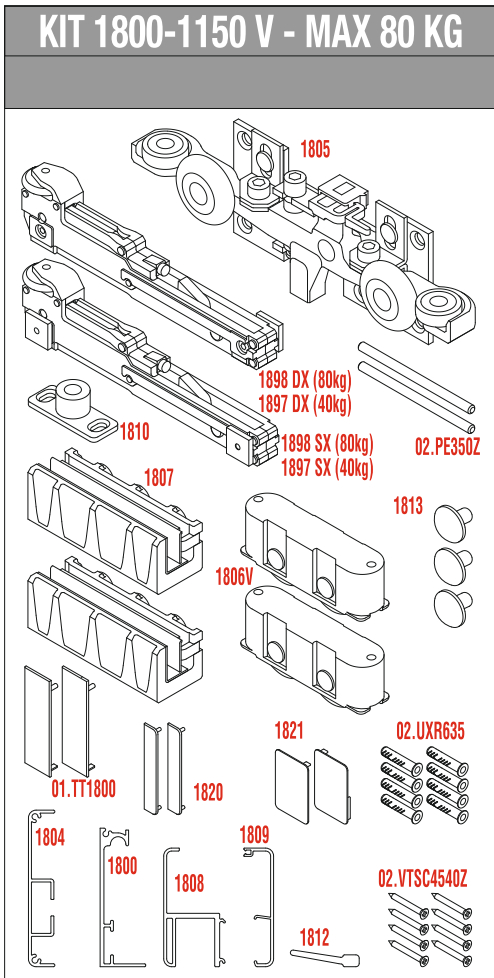

### Legenda KIT / Kit Legend

<b>1805</b>	Guida superiore regolabile Adjustable upper truck
<b>02.PE350Z</b>	Perno Pin
<b>1898 DX-SX</b>	Decelerante DX-SX (80kg) Soft Closing Stopper R-L (80kg)
<b>1897 DX-SX</b>	Decelerante DX-SX (40kg) Soft Closing Stopper R-L (40kg)
<b>1810</b>	Guida inferiore Lower runner
<b>1806V</b>	Carrello inferiore Vetro Glass Lower truck
<b>1807</b>	Pinza Vetro Glass Clamp
<b>1813</b>	Borchia Vetro Glass Stud
<b>01.TT1800</b>	Tappo terminale End cover
<b>1820</b>	Tappo terminale End cover
<b>1821 DX-SX</b>	Tappo Terminale DX-SX End Cover R-L
<b>02.UXR635</b>	Tassello Dowel
<b>02.VTSC4540Z</b>	Vite 4.5x40 Screw 4.5x40
<b>1812</b>	Labbro Parapolvere L=1150mm Dust Lip L=1150mm
<b>1800</b>	Profilo superiore L=1150mm Upper profile L=1150mm
<b>1808</b>	Profilo inferiore L=1150mm Lower profile L=1150mm
<b>1809</b>	Copertura inferiore l=1150mm Lower Cover L=1150mm
<b>1804</b>	Copertura superiore L=1150mm Upper Cover L=1150mm

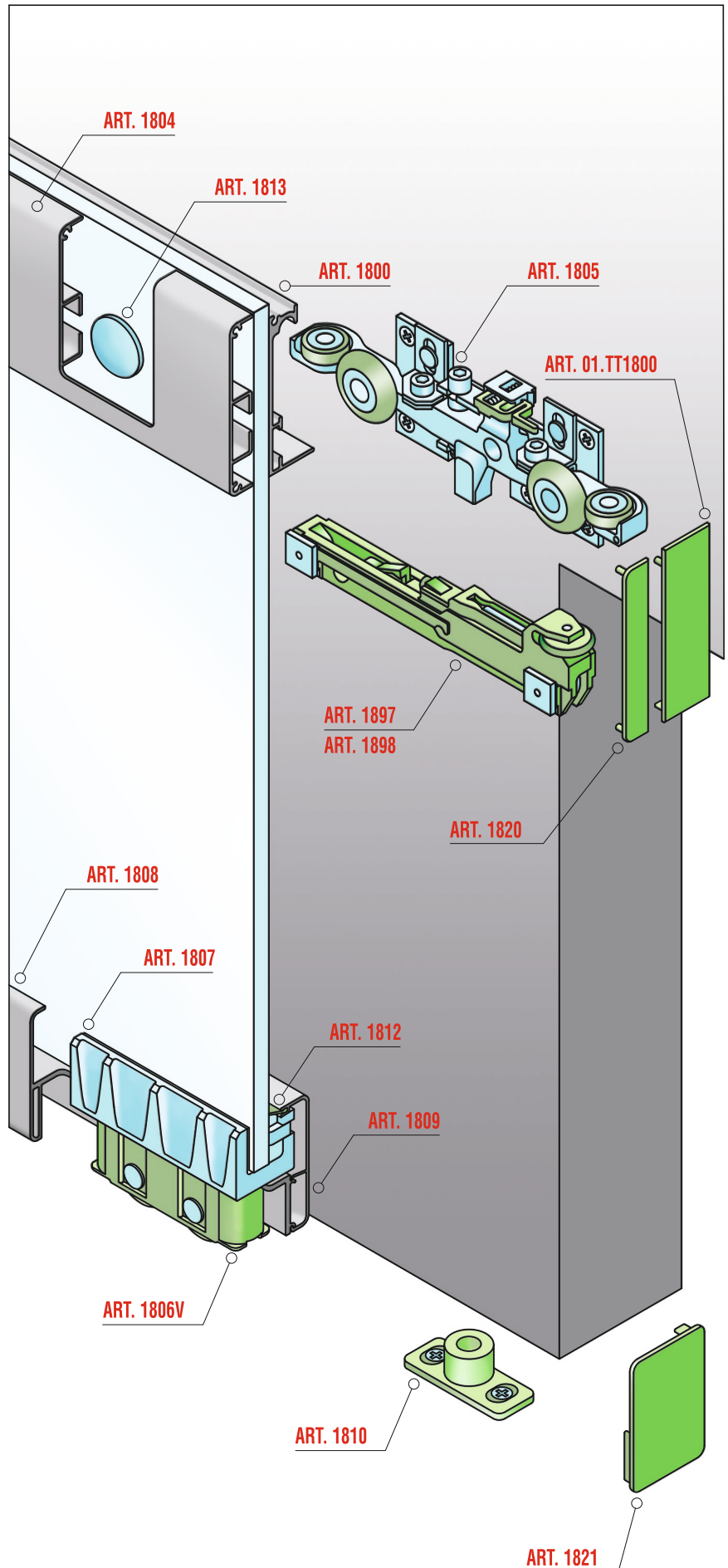



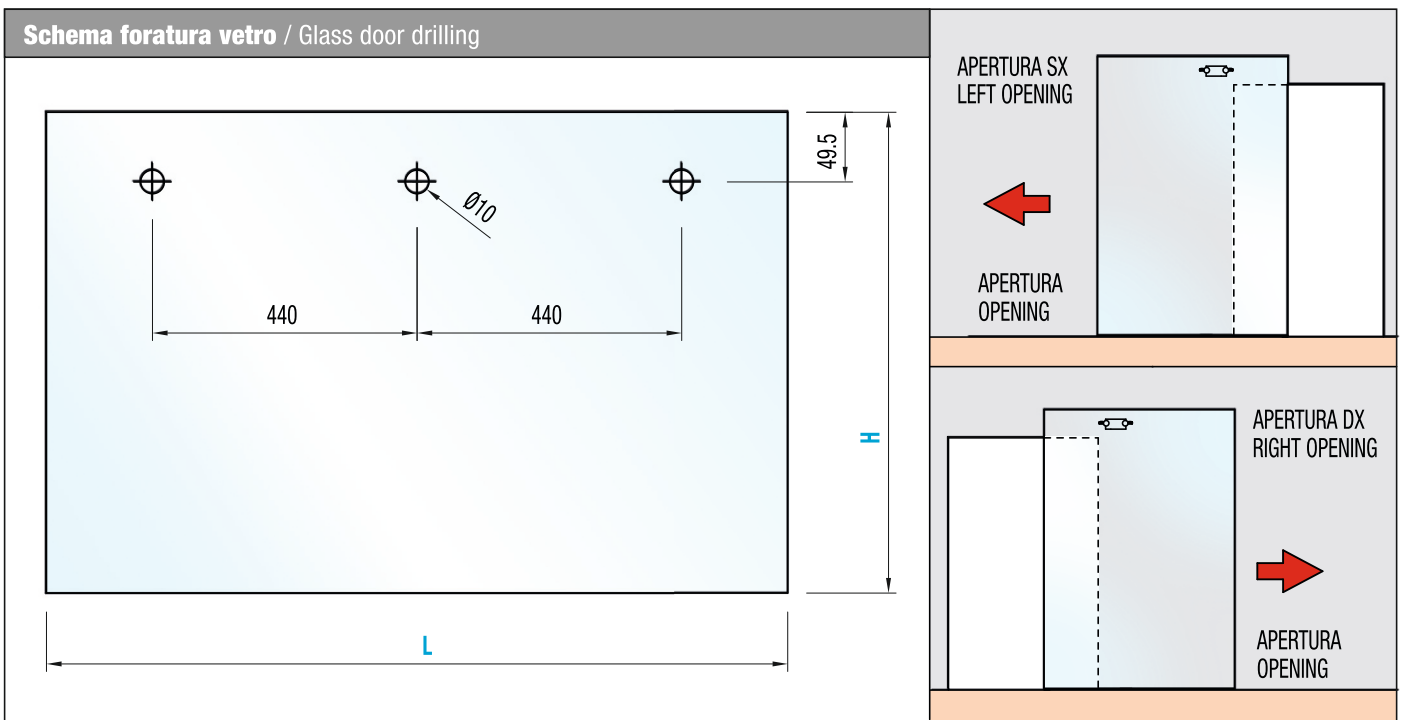
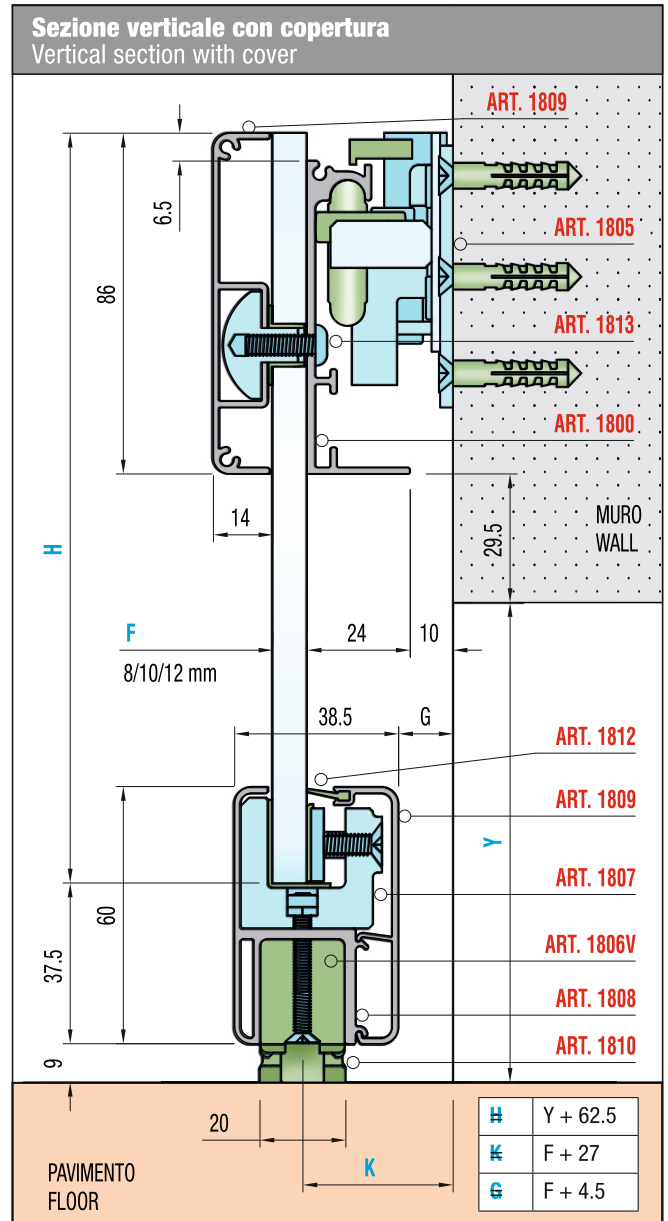
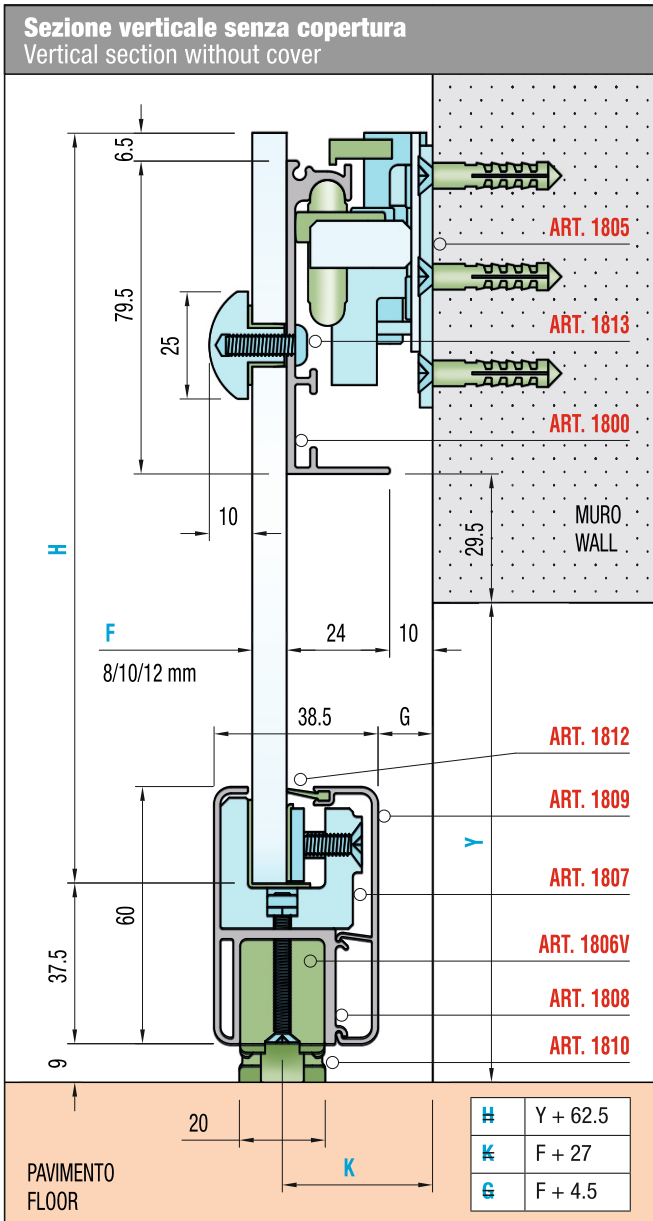



## Dimensioni standard per porta ad apertura completa del vano

Standard dimensions for door with complete doorway opening

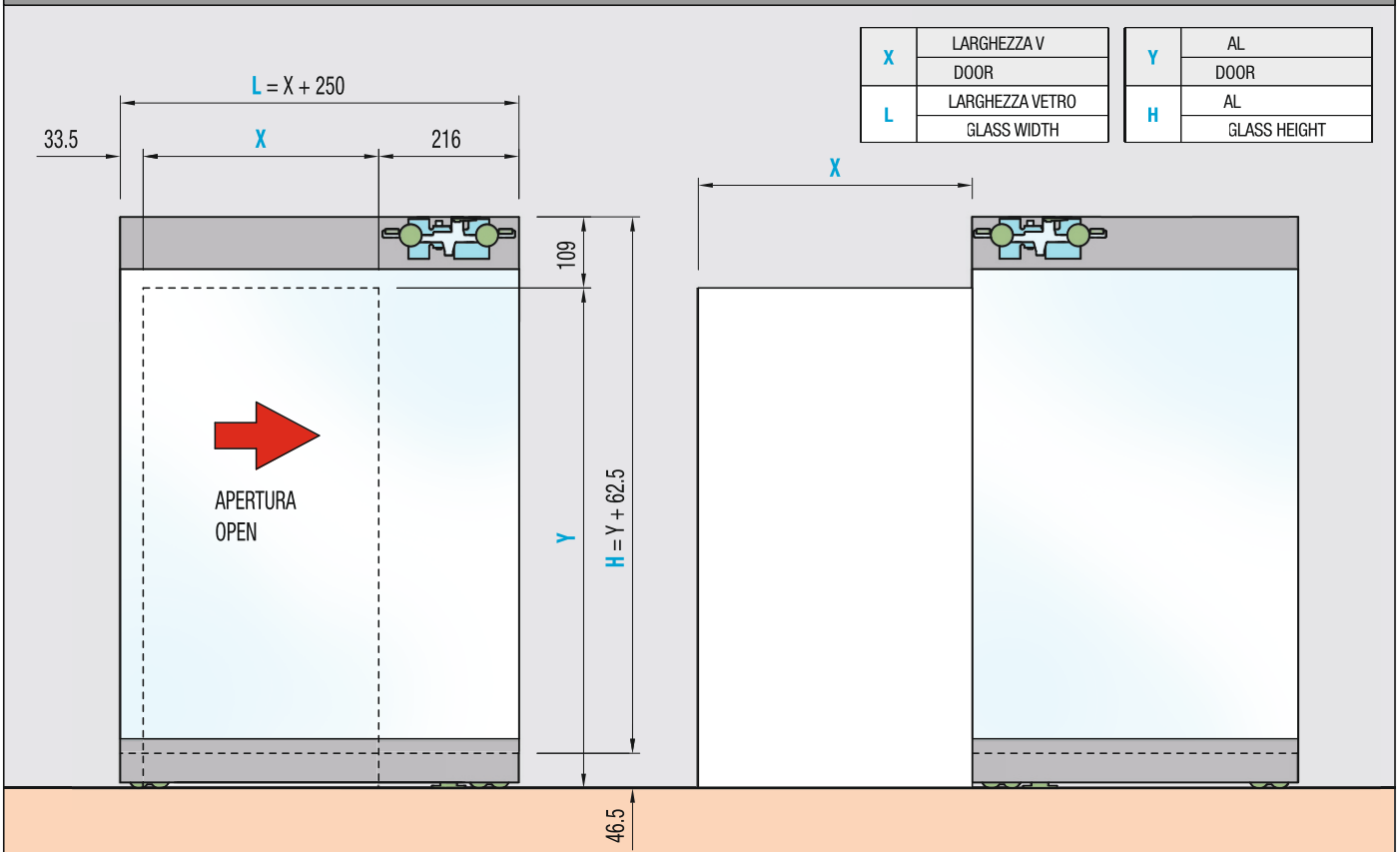

## Dimensioni standard per porta ad apertura parziale del vano

Standard dimensions for door with partial doorway opening

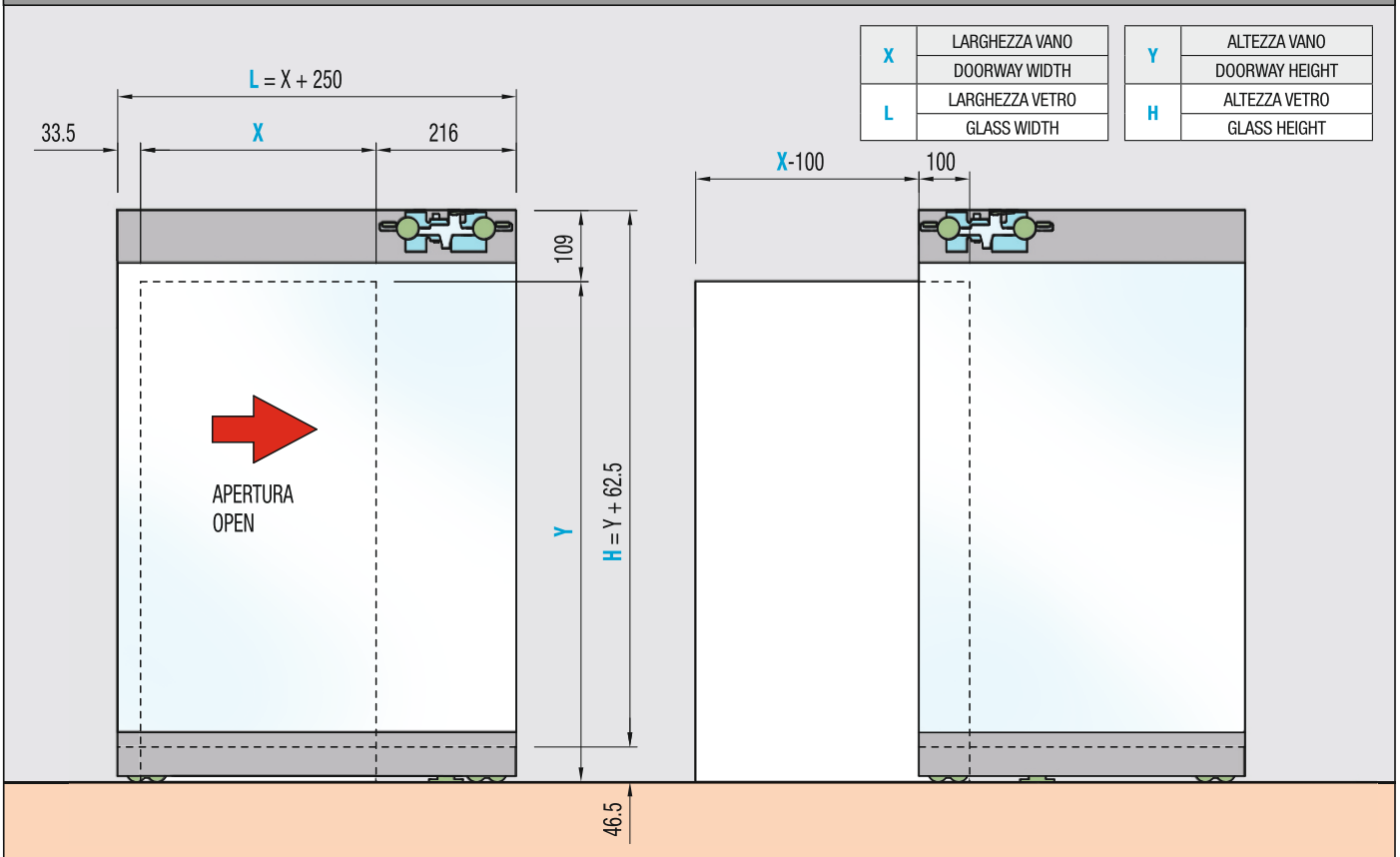

## Posizione guida superiore e inferiore / Upper and lower guide position

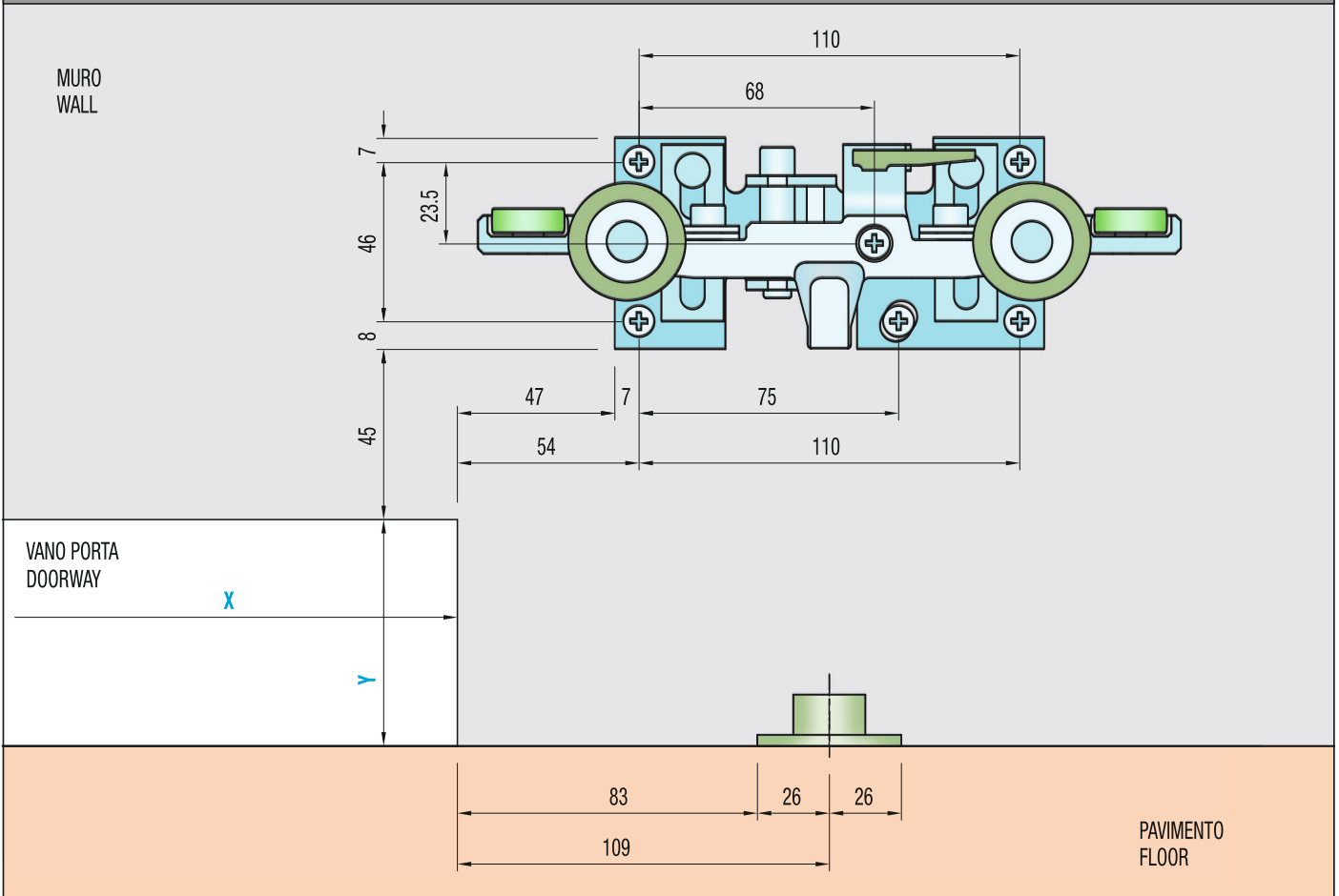

## Posizione fermi ammortizzati per apertura completa / Soft closing position for complete opening



## Posizione fermi ammortizzati per apertura parziale / Soft closing position for partial opening

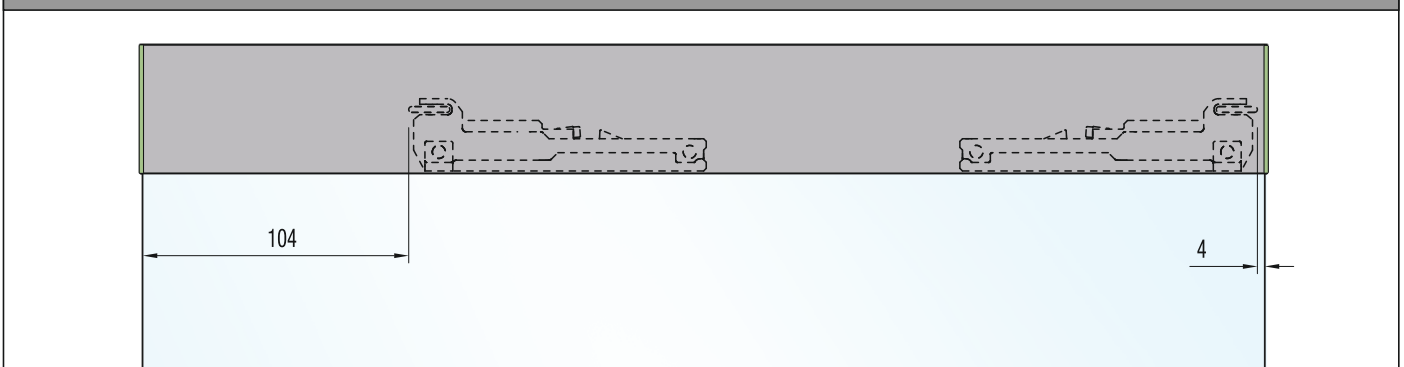

## Dispositivo di riarmo automatico / Automatic self activating device

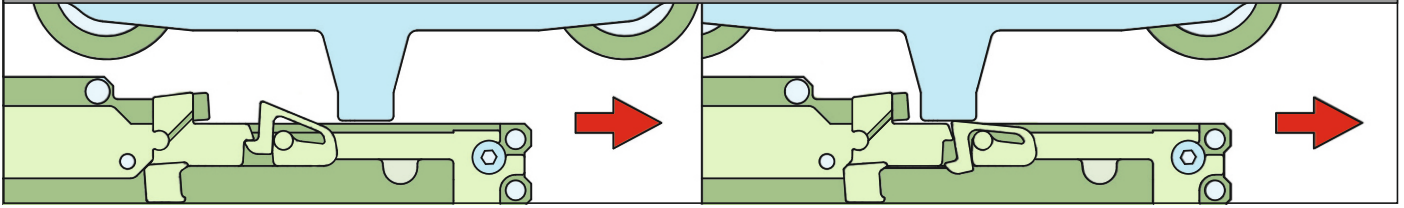

## Istruzioni di montaggio / Assembly instructions

1

Posizionare la mezziera della porta in corrispondenza della guida fissata a muro. Controllare che l'antiscambiamento non sia attivato come da figure sottostanti. Fit the center line of the door close to the upper truck previously fastened to the wall. Check that the clasp is not triggered, as shown in the figures below.

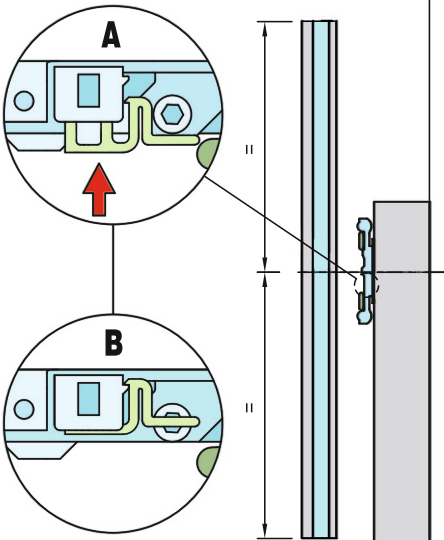

2

Posizionare la porta a cavallo della guida ART. 1810 facendo poggiare a terra le ruote inferiori. Position the door astride the runner ART. 1810 lying the lower wheels on the ground.

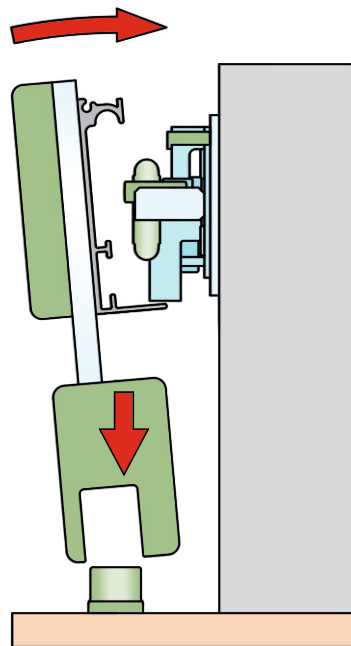

3

Mettere la porta in posizione verticale facendo poggiare il profilo alle ruote della staffa superiore. Mantenere la porta spinta contro la staffa superiore sino a fine montaggio. Put the door in a vertical position, placing its profile on the wheels of the upper truck. Keep the door pushed against the upper truck till the end of the assembly.

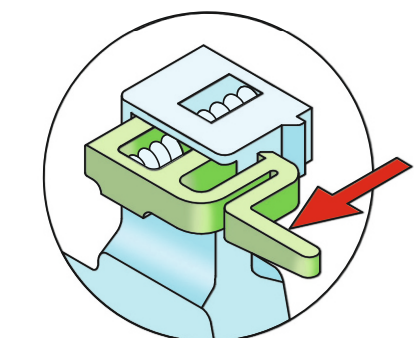
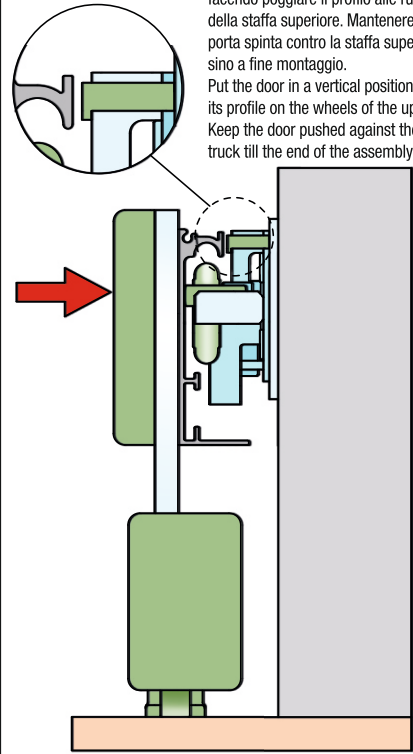

4 Tirare la leva dell'antiscambiamento. Pull the lever of the clasp.

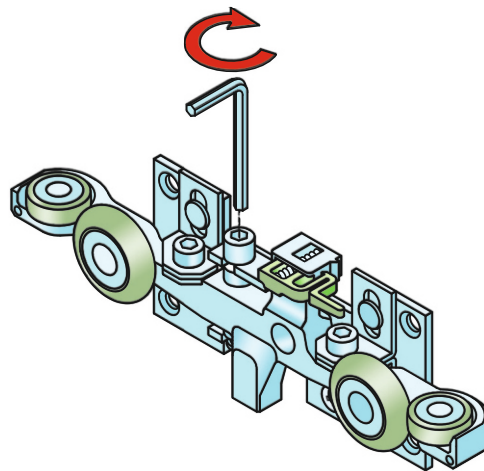

6 Avvitare la vite di regolazione dell'altezza della staffa a parete. Fasten the screw for the adjustment of wall bracket height.

Il bilanciamento sale avvicinando le ruote al profilo. The rocker arm rises, moving the wheels closer to the profile.

Quando l'antiscambiamento emette un sonoro "Click", smettere di avvitare. When the clasp makes a loud "Click", stop fastening.

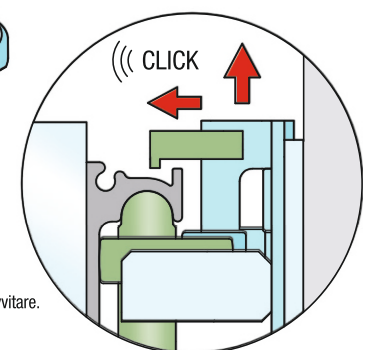
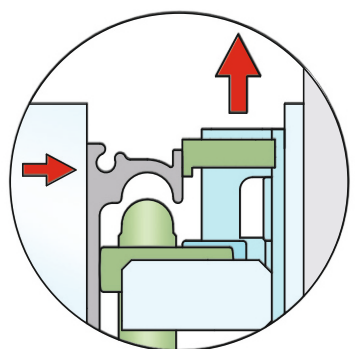

5

L'antiscambiamento va automaticamente in appoggio al profilo superiore. The clasp will automatically lie on the upper profile.

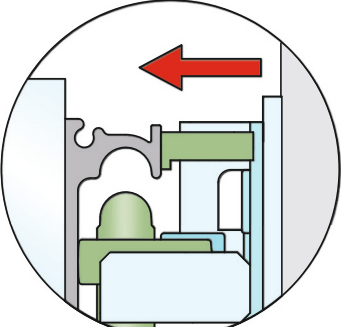

## Regolazione allineamento porta/muro / Door/Wall alignment adjustment

7

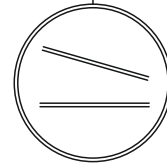
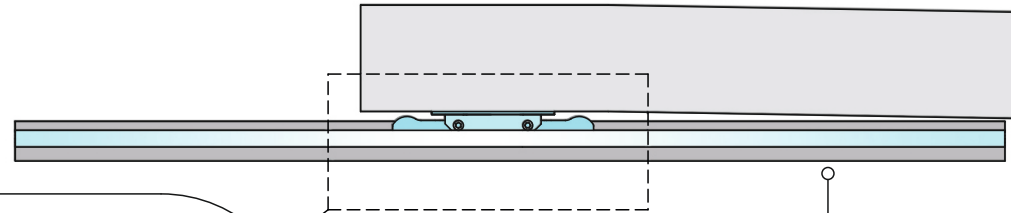
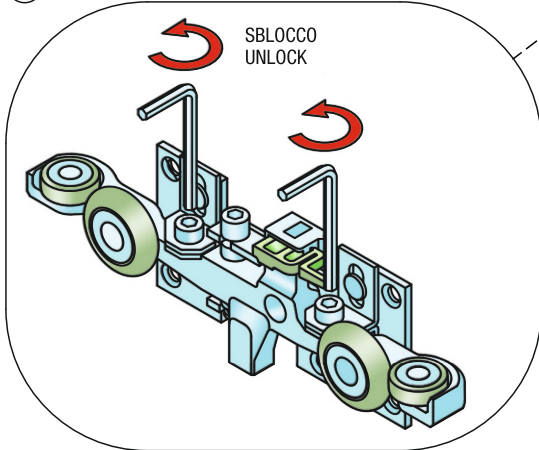

SE LA PORTA NON PARALLELA AL MURO  
SVITARE LE 2 APPOSITE VITI DI BLOCCAGGIO

IF THE DOOR IS NOT ALIGNED WITH THE WALL  
LOOSEN THE FIXING SCREWS

8

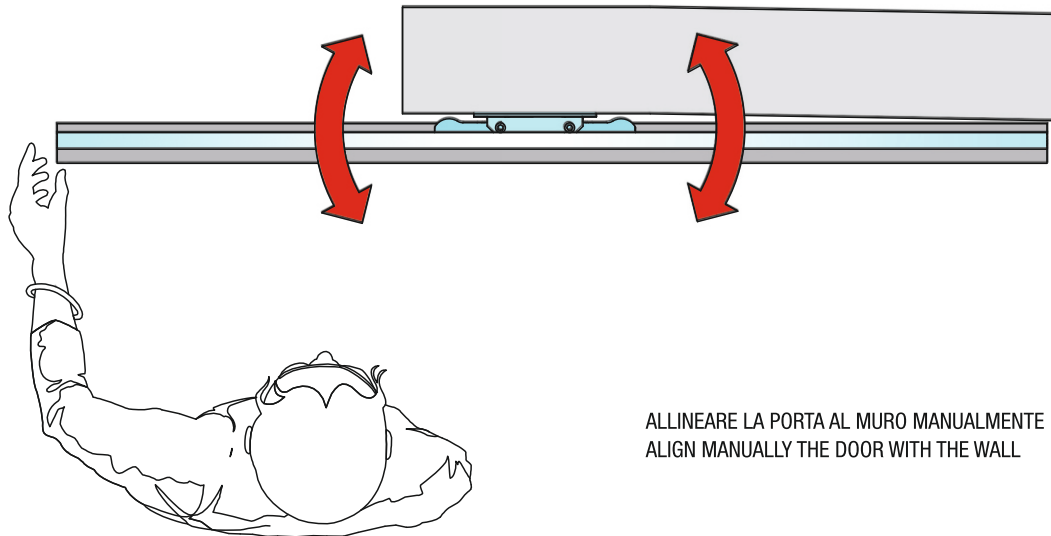

ALLINEARE LA PORTA AL MURO MANUALMENTE  
ALIGN MANUALLY THE DOOR WITH THE WALL

9

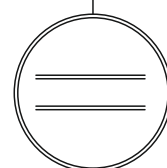
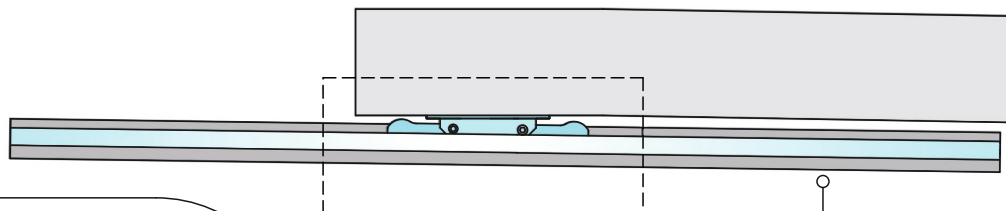
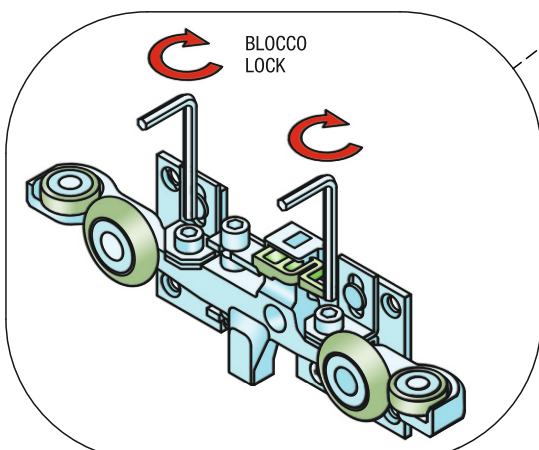

BLOCCARE L'ALLINEAMENTO SERRANDO LE DUE VITI DI FISSAGGIO  
LOCK THE ALIGNMENT SCREWING THE FIXING SCREWS

## Механизъм за интериорна плъзгаща плътна врата с плавно отваряне и затваряне Серия 1000

**/комплект за отвор 1 метър, до 40 кг врата - 169.80 лв с ДДС/**

### KIT 0138-0197 - MAX 40 KG

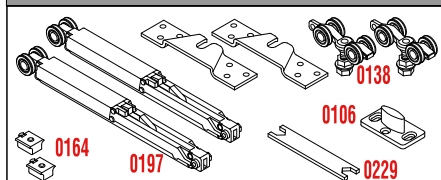



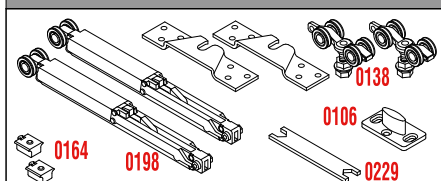

### KIT 0138-0198 - MAX 100 KG



#### Kit Legend

<b>0134</b>	Carrello con 2 cuscinetti Truck with 2 ball-bearings
<b>0138</b>	Carrello con 4 cuscinetti Truck with 4 ball-bearings
<b>0197</b>	Decelerante fino a 40kg Soft Closing Stopper up to 40kg
<b>0198</b>	Decelerante fino a 100kg Soft Closing Stopper up to 100kg
<b>0164</b>	Attivatore Activator
<b>0106</b>	Guida inferiore fissa Fixed lower runner
<b>0229</b>	Chiave di regolazione mm 7-16 Adjusting spanner mm 7-16

#### Legend other items

<b>0195</b>	 40/80кг	Profilo alluminio superiore Upper aluminium profile
<b>0196</b>	 120кг	Profilo alluminio superiore Upper aluminium profile
<b>0251</b>		Profilo alluminio inferiore Lower aluminium profile
<b>0189</b>		Staffa a parete regolabile Adjustable wall bracket

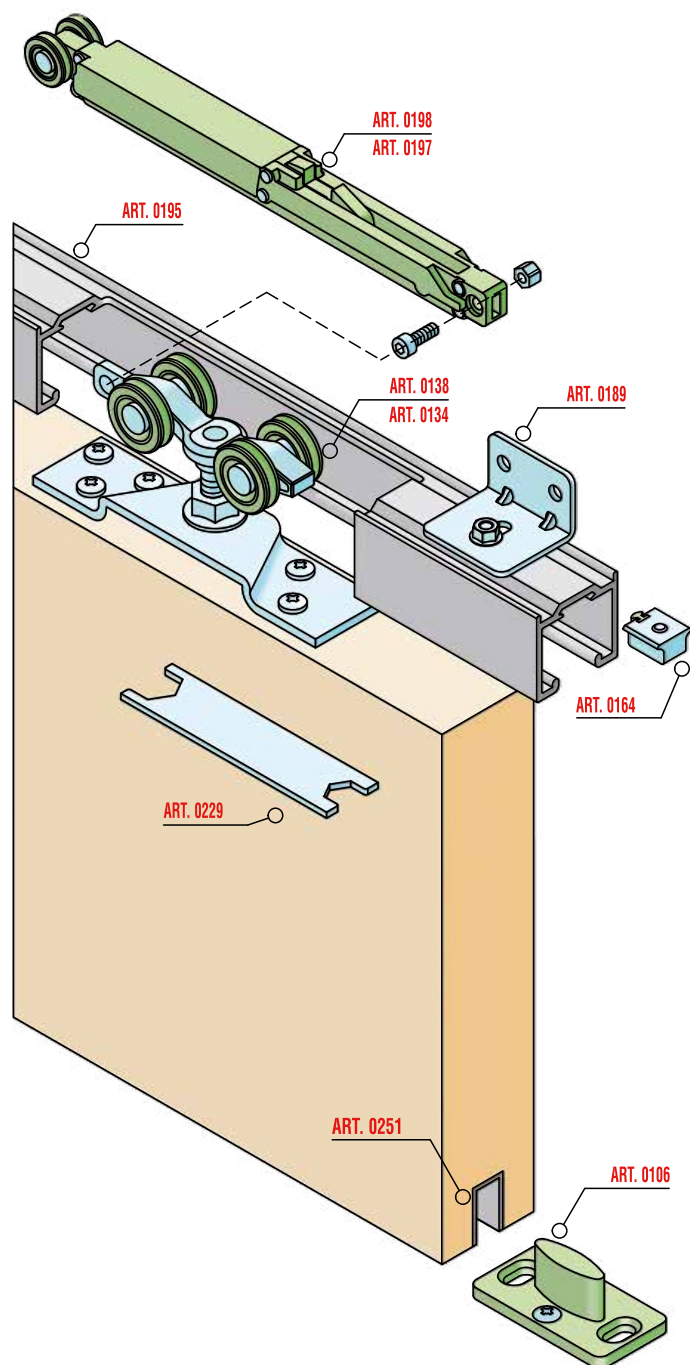

Комплект за врата до 120 кг. - код: **742-0138P** - **52.20 лв.**

Амортисьори до 40 кг. комплект 2 бр. - код: **742-KIT0197** - **54,60 лв.**

Амортисьори до 100 кг. комплект 2 бр. - код: **742-KIT0198** - **67,70 лв.**

Долен профил за вкопаване - код: **742-0251GF** - **12,00 лв./м**

Релса плъзгане до 80 кг. - код: **742-0195AF** - **20,00 лв./м** - налична на 6 метра

Релса плъзгане до 120 кг. - код: **742-0196AF** - **32,00 лв./м** - налична на 6 метра

L-образна планка за стена - код: **742-0189** - **2,20 лв./брой**

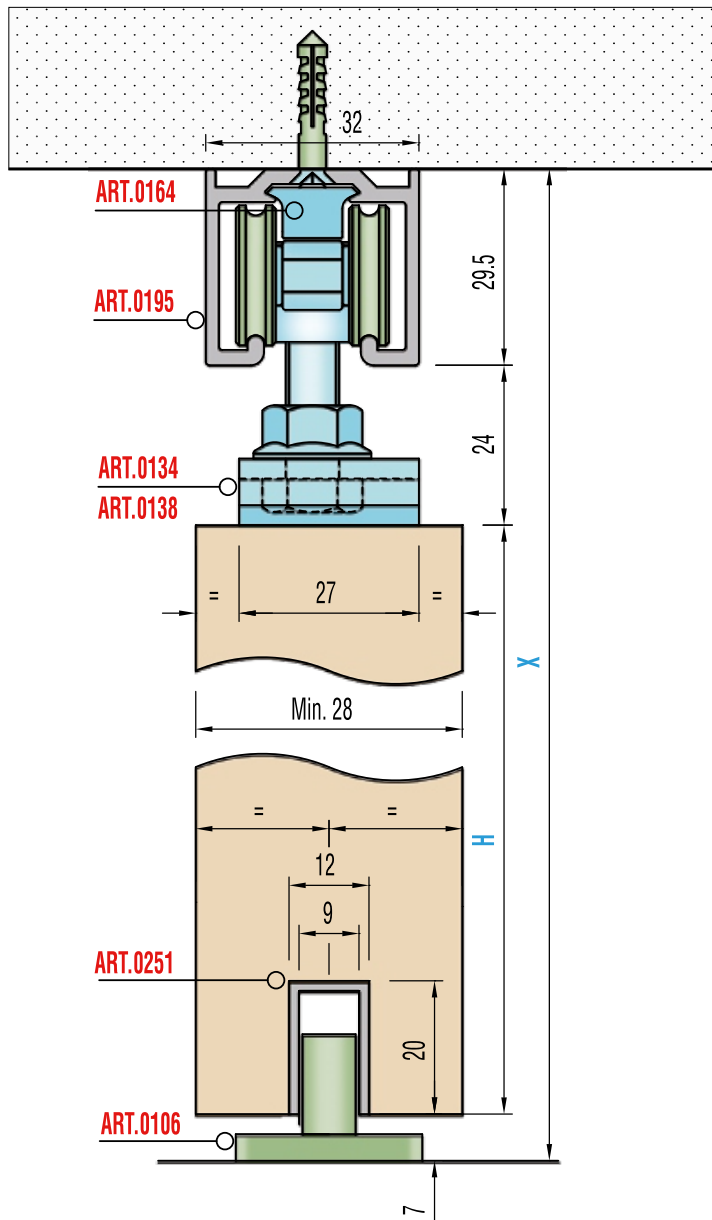

Peso massimo anta Kg. 40 (KIT 0134-0197)  
Maximum door weight Kg 40 (KIT 0134-0197)

Peso massimo anta Kg. 80 (KIT 0138-0198)  
Maximum door weight Kg 80 (KIT 0138-0198)

H = X - 60.5

Distanza minima porta - binario  
Minimum distance between door and profile

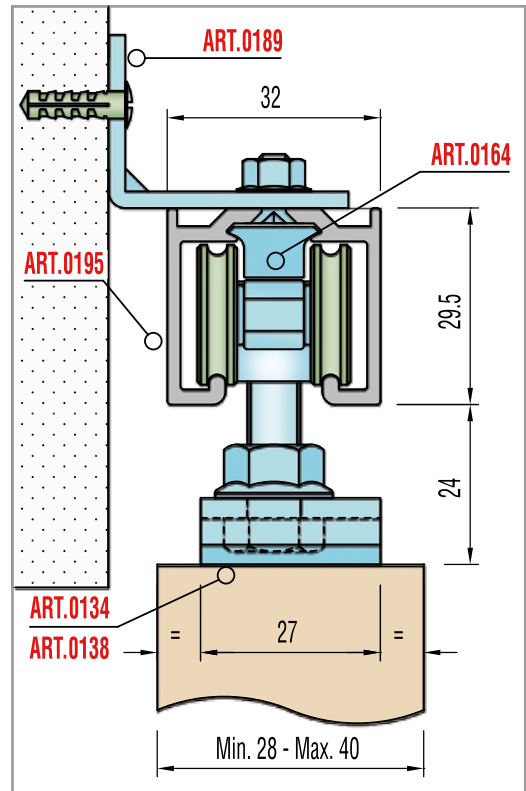

A	B
larghezza porta - length of the door	lunghezza binario - length of the track
500-700 mm.	1100 mm.
710-900 mm.	1500 mm.
900-1000 mm.	1700 mm.
910-1200 mm.	1900 mm.

## Dimensioni standard / Standard dimensions

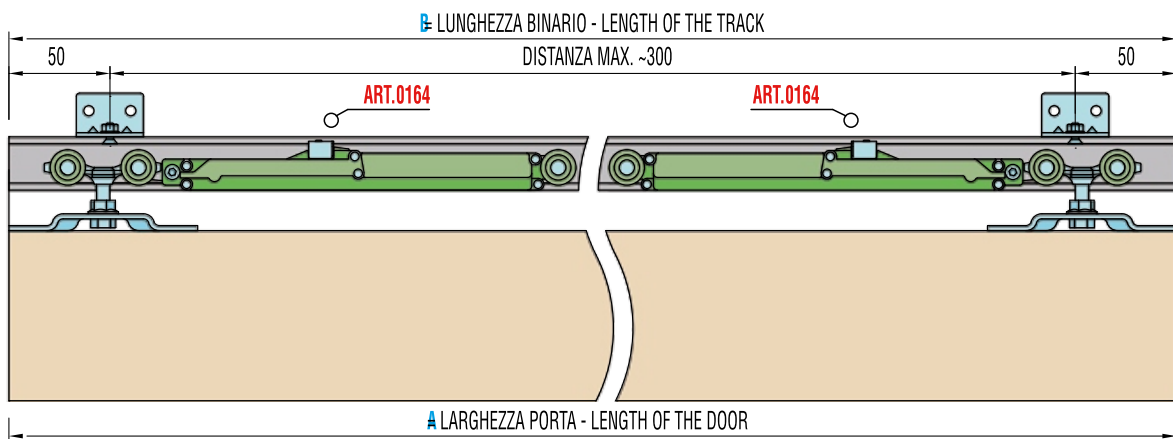



**LARGHEZZA MINIMA PORTA CON SISTEMA STANDARD / MINIMUM DOOR WIDTH WITH STANDARD SYSTEM**

Min. 680 mm

---

**LARGHEZZA MINIMA PORTA CON SISTEMA IBRIDO AMMORTIZZATO/STATICO / MINIMUM DOOR WIDTH WITH SOFT CLOSING MIX SYSTEM**

20 min  
Min. 465 mm

---

**DISPOSITIVO DI RIARMO AUTOMATICO / AUTOMATIC SELF ACTIVATING DEVICE**

<b>0134</b>	Carrello con 2 cuscinetti <i>Truck with 2 ball-bearings</i>
<b>0138</b>	Carrello con 4 cuscinetti <i>Truck with 4 ball-bearings</i>
<b>0197</b>	Decelerante fino a 40kg <i>Soft Closing Stopper up to 40kg</i>
<b>0198</b>	Decelerante fino a 100kg <i>Soft Closing Stopper up to 100kg</i>
<b>0164</b>	Attivatore <i>Activator</i>
<b>0106</b>	Guida inferiore fissa <i>Fixed lower runner</i>
<b>0195</b>	Profilo alluminio superiore <i>Upper aluminium profile</i>
<b>0196</b>	Profilo alluminio superiore <i>Upper aluminium profile</i>
<b>0251</b>	Profilo alluminio inferiore <i>Lower aluminium profile</i>

**1** Inserire il carrello nella sede del decelerante. Inserire la vite M5 di bloccaggio. Serrare il relativo dado cieco M5.  
*Insert the truck in the soft closing housing, Insert M5 screw and lock the M5 nut.*

**2** Inserire carrello e decelerante premontati nel relativo binario guida, assemblare il carrello alla staffa di tenuta premontata sulla porta e regolarne successivamente la verticalita' tramite l'apposita chiave.  
*Insert preassembled truck and soft closing device in their profile, assemble the truck to the preassembled sealing bracket of the door, and then adjust the verticality of the door thanks to the special key.*

**3** Inserire l'attivatore nel binario guida nella posizione desiderata serrandolo attraverso il relativo grano di bloccaggio.  
*Insert the activator in the profile in the right position and fix it thanks to its locking screw.*

**ATTENZIONE**  
Bloccare sempre l'attivatore Art.0164 tramite l'apposito grano M5 prima di agganciarlo al decelerante

**WARNING**  
Always lock the activator Art.0164 by the relative screw before hooking it to the soft closing device

## Механизъм за интериорна плъзгаща стъклена врата с плавно отваряне и затваряне Серия 1000



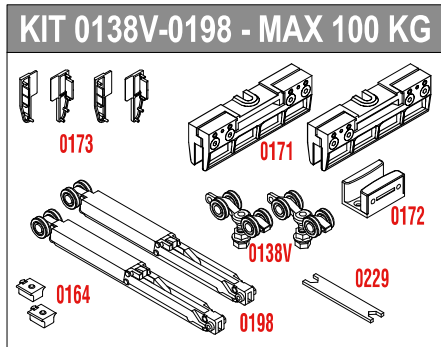

**/комплект за отвор 1 метър, до 40 кг врата - 268.90 лв с ДДС/**



### Kit Legend

<b>0138V</b>	Carrello con 4 cuscinetti Truck with 4 ball-bearings
<b>0198</b>	Decelerante fino a 100kg Soft Closing Stopper up to 100kg
<b>0164</b>	Attivatore Activator
<b>0171</b>	Supporto a pinza per vetro Glass Support
<b>0172</b>	Guida inferiore Lower guide
<b>0173</b>	Tappo x copertura ART.0170 DX-SX Plug for cover ART.0170 DX-SX
<b>0170/1</b>	Copertura alluminio 156mm Aluminium cover 156mm
<b>0229</b>	Chiave di regolazione mm 7-16 Adjusting spanner mm 7-16

### Legend other items

<b>0196</b>	 Profilo alluminio superiore Upper aluminium profile
<b>0195</b>	 Profilo alluminio superiore Upper aluminium profile
<b>0170</b>	 Copertura in alluminio Aluminium cover
<b>0189</b>	 Staffa a parete regolabile Adjustable wall bracket

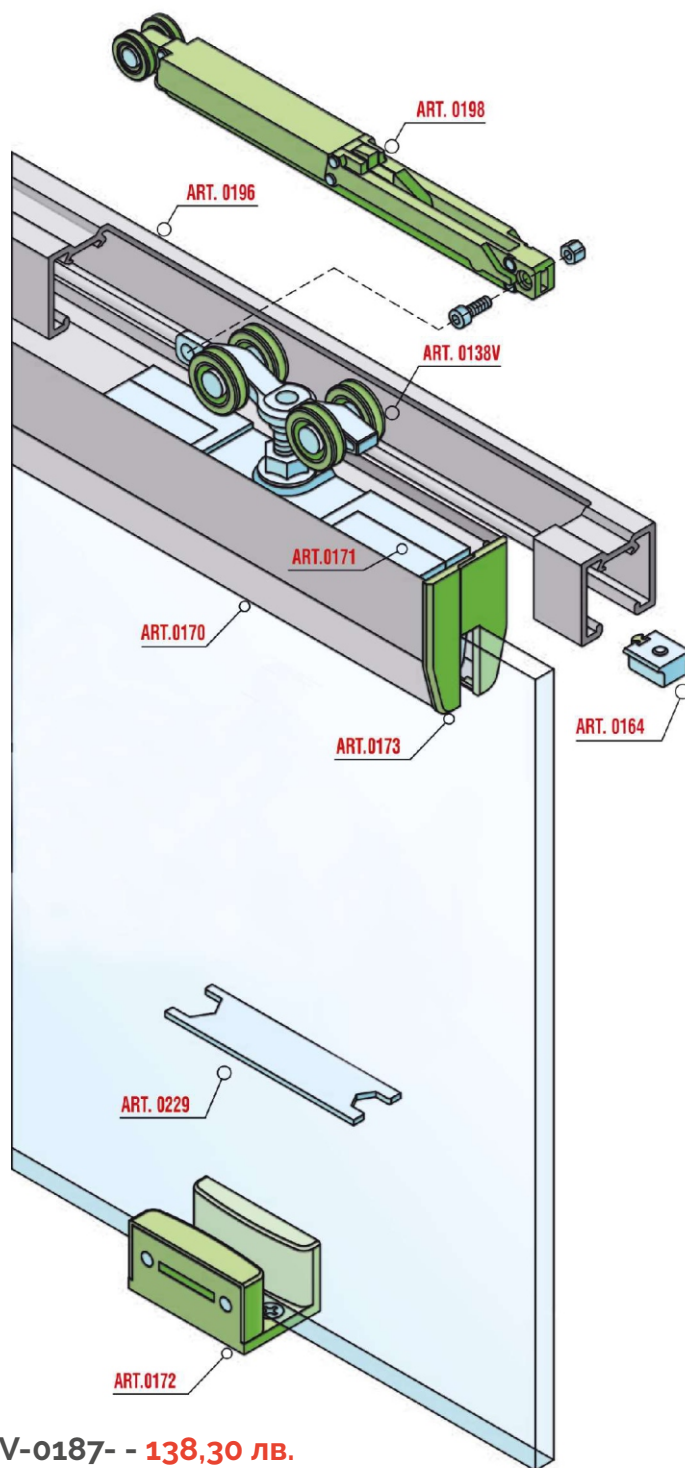

Комплект за врата до 100 кг. - код: 742-0138V-0187- - **138,30 лв.**

Амортисьори до 40 кг. комплект 2 бр. - код: 742-KIT0197 - **54,60 лв.**

Амортисьори до 100 кг. комплект 2 бр. - код: 742-KIT0198 - **67,70 лв.**

Декоративен капак - код: 742-0170A - **13,00 лв./м** - наличен на 3 метра

Релса плъзгане до 80 кг. - код: 742-0195AF - **20,00 лв./м** - налична на 6 метра

Релса плъзгане до 120 кг. - код: 742-0196AF - **32,00 лв./м** - налична на 6 метра

L-образна планка за стена - код: 742-0189 - **2,20 лв./брой**

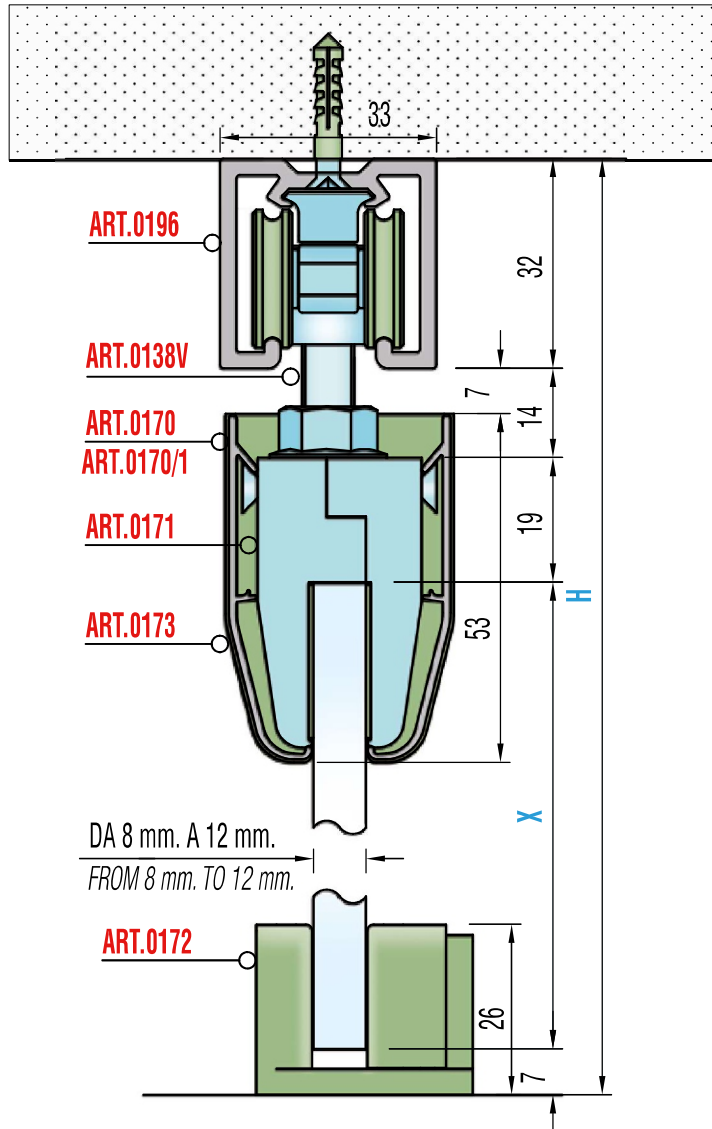

Peso massimo anta Kg. 100  
Maximum door weight Kg 100

H = X - 72

SCHEMA DI MONTAGGIO COPERTURA  
COVER ASSEMBLING INSTRUCTIONS

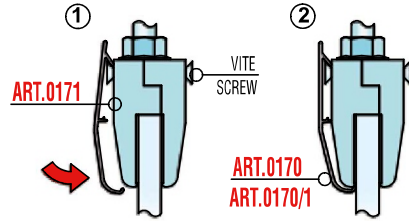

DIMENSIONI GUIDA / GUIDE DIMENSION

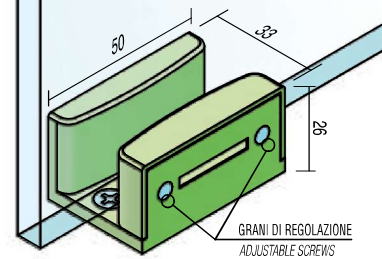

NO

SI - YES

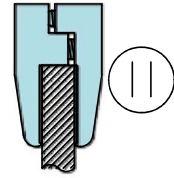
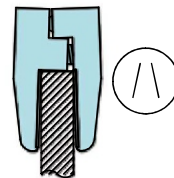

Per la tenuta del sistema verificare il parallelismo a pinza chiusa  
Check the parallelism clamp in the assembled

Dimensioni standard / Standard dimensions

A	B
larghezza porta - length of the door	lunghezza binario - length of the track
500-700 mm.	1100 mm.
710-900 mm.	1500 mm.
900-1000 mm.	1700 mm.
910-1200 mm.	1900 mm.

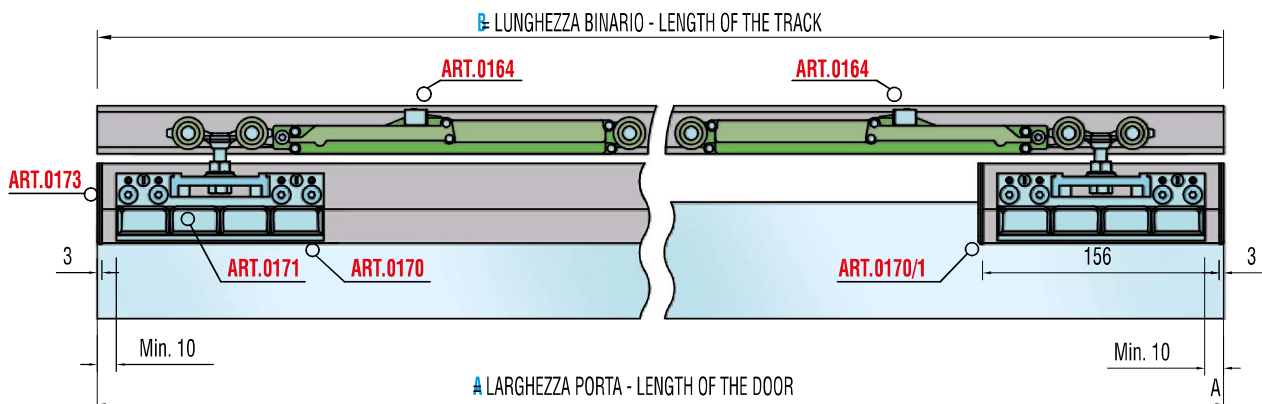

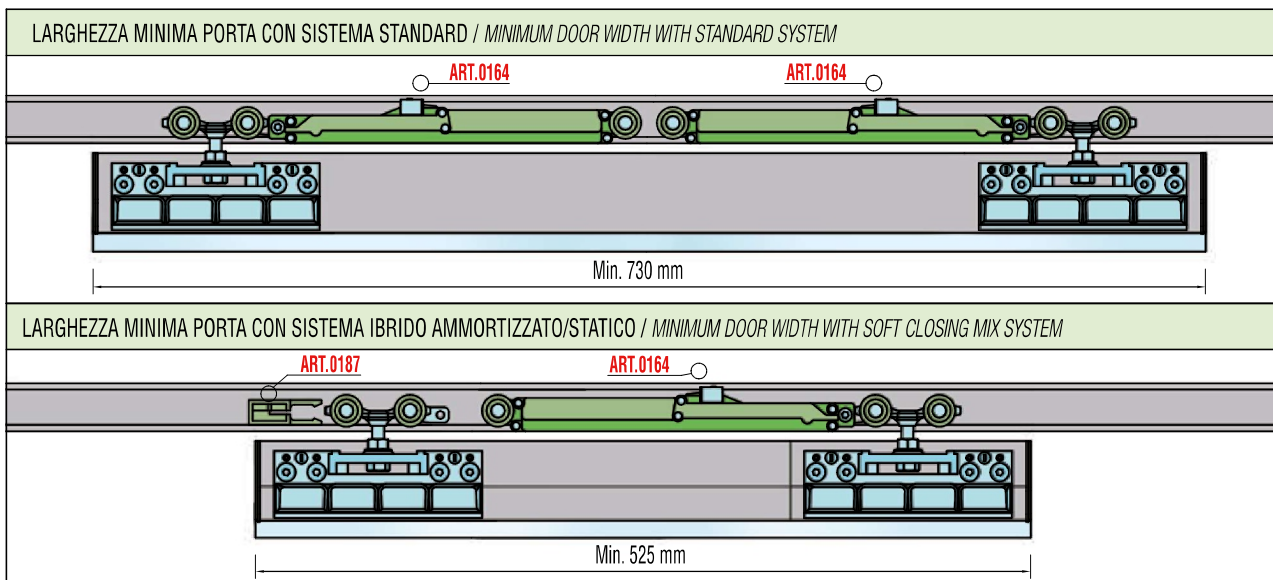

SCHEMA FORATURA ANTE VETRO PER MONTAGGIO ART.0171 / GLASS DOOR DRILLING TO FIT ART.0171

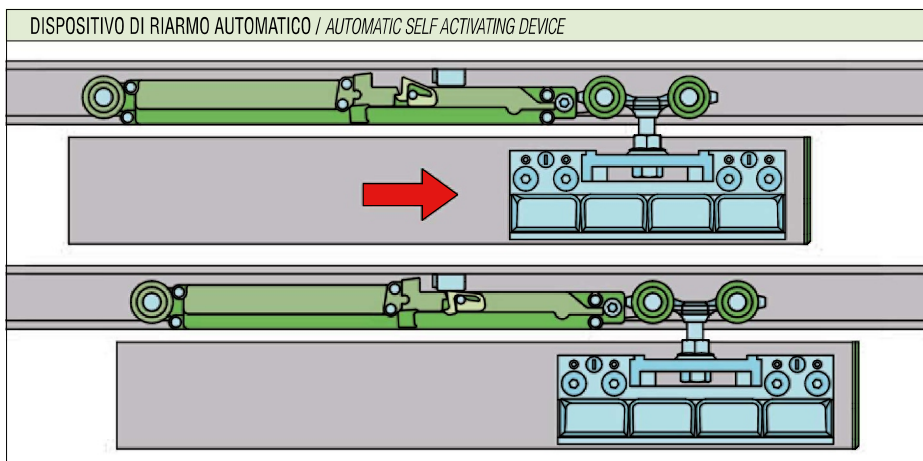
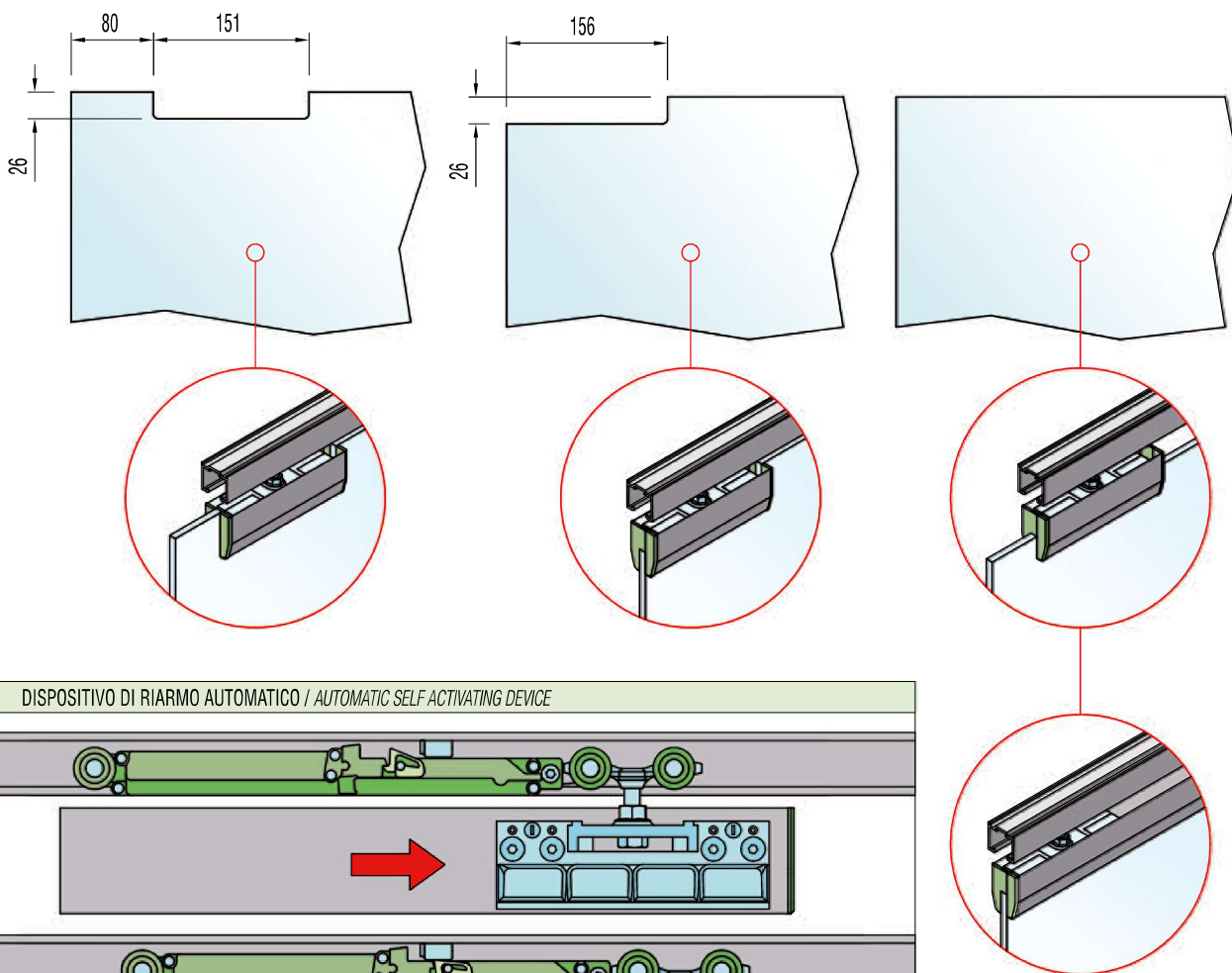



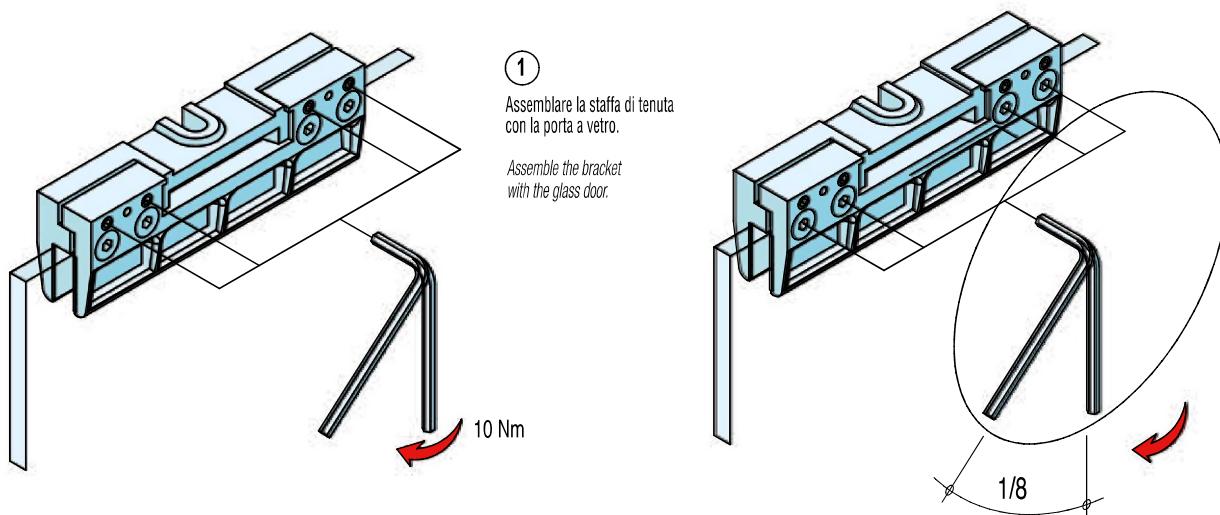

①  
Assemblare la staffa di tenuta  
con la porta a vetro.

*Assemble the bracket  
with the glass door.*

10 Nm

1/8

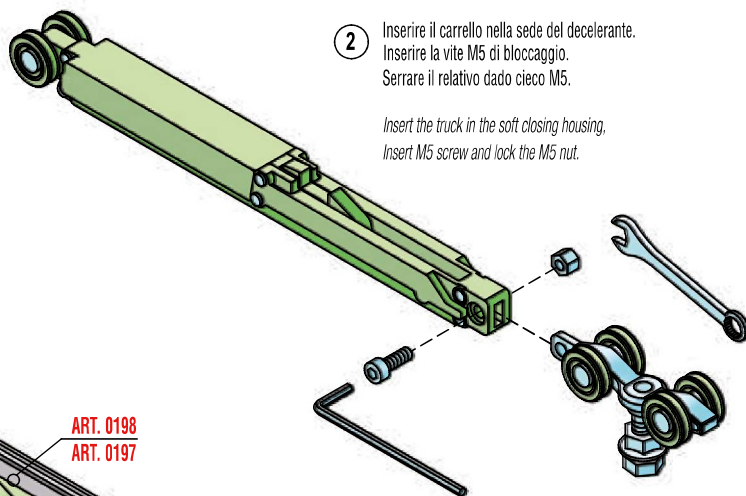

② Inserire il carrello nella sede del decelerante.  
Inserire la vite M5 di bloccaggio.  
Serrare il relativo dado cieco M5.

*Insert the truck in the soft closing housing,  
Insert M5 screw and lock the M5 nut.*

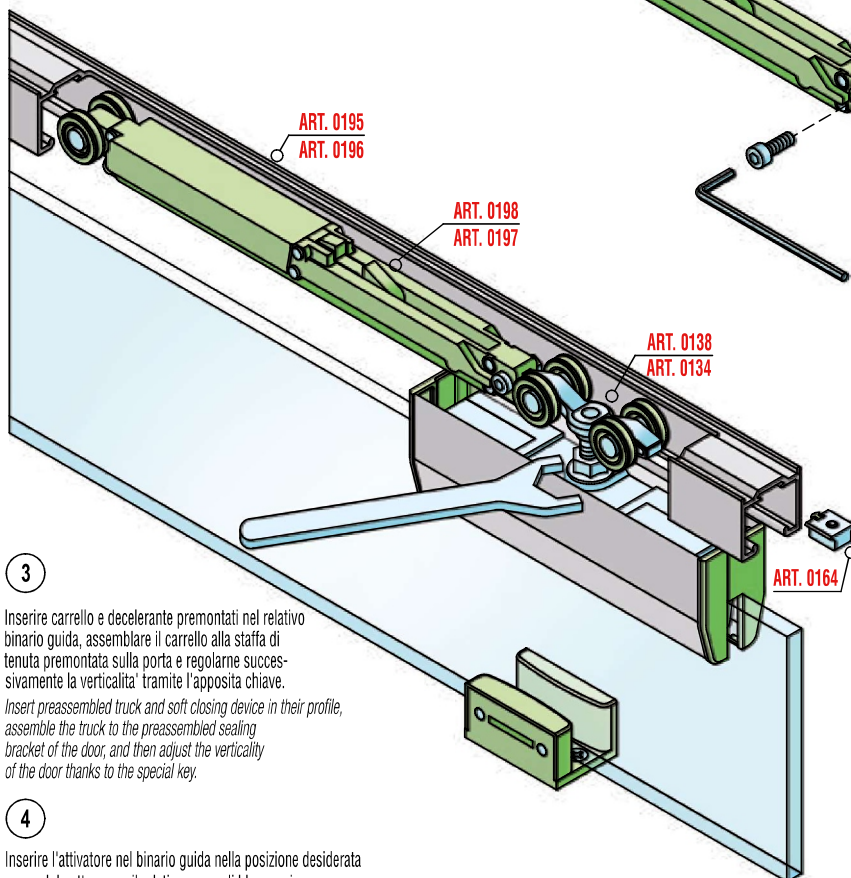

③

Inserire carrello e decelerante premontati nel relativo binario guida, assemblare il carrello alla staffa di tenuta premontata sulla porta e regolarne successivamente la verticalità tramite l'apposita chiave.

*Insert preassembled truck and soft closing device in their profile, assemble the truck to the preassembled sealing bracket of the door, and then adjust the verticality of the door thanks to the special key.*

④

Inserire l'attivatore nel binario guida nella posizione desiderata serrandolo attraverso il relativo grano di bloccaggio.

*Insert the activator in the profile in the right position and fix it thanks to its locking screw.*

### ATTENZIONE

Bloccare sempre l'attivatore Art.0164 tramite l'apposito grano M5 prima di agganciarlo al decelerante

### WARNING

*Always lock the activator Art.0164 by the relative screw before hooking it to the soft closing device*

## Плъзгаща система **ESBERG** с за интериорна стъклена врата с плавно отваряне и затваряне , до 80 и 130 кг.

Цена за комплект за 1 плъзгаща врата с плавно отваряне, монтаж пред отвор, декоративен капак 75 мм, до 80 кг  
Широчина на вратата до 1 000 мм  
/2 метра релса и капак/

Цена: **464,00 лв с ДДС** /без дръжка/

**/минимална широчина на вратата 632 mm./**

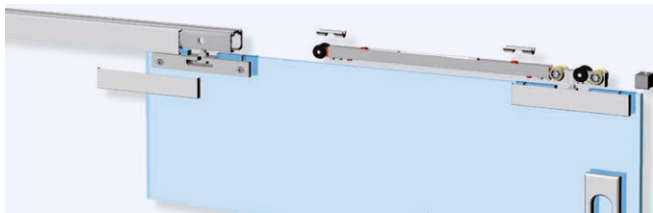

### Цени ка компоненти:

Комплект елементи за 1 врата до 80 кг - Код: **02-5882** - **278,00лв. с ДДС**

Комплект елементи за 1 врата до 130 кг - Код: **02-5882/130** - **326,00лв. с ДДС**  
 комплекта включва - 2 лапи за стъкло, комплект колички с амортисьор, 2 стопера, 2 активатора, подов водач, **НЕ** включва дръжка/

Релса за плъзгане, алуминий - Код: **02-5801/A-6** - **57,00лв./метър**

Профил за фиксирано стъкло, алуминий - Код: **02-5803/A** - **21,10 лв/метър**

Покриващ капак 75 мм, алуминий - Код: **02-5808/A-6** - **24,70 лв/метър**

Покриващ капак 100 мм, алуминий - Код: **02-5810/A-6** - **28,60 лв/метър**

Четка 13 мм за в долния край на капака, сива - Код: **02-4109** - **1,50 лв/метър**

Странични капачки за релса и капак 75 мм, алуминий - Код: **02-5838/A** - **19,90 лв**

/използват се при монтаж на стена пред отвор, за комплект/

Странични капачки за релса и капак 100 мм, алуминий - Код: **02-5830/A** - **19,90 лв**

/използват се при монтаж на стена пред отвор, за комплект/

**Заб.:** - /релси и капаци налични на 6 метра/

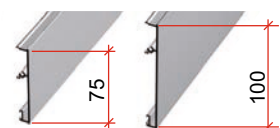
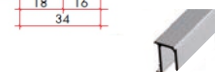
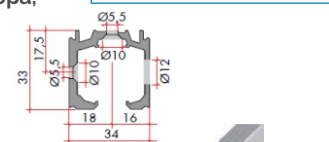
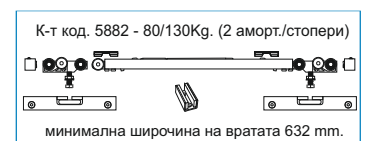



## Плъзгаща система **ESBERG** с за стъклена врата

### Разрези/изгледи/размери

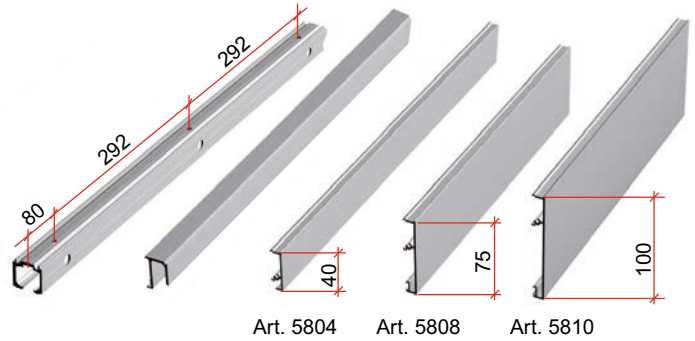
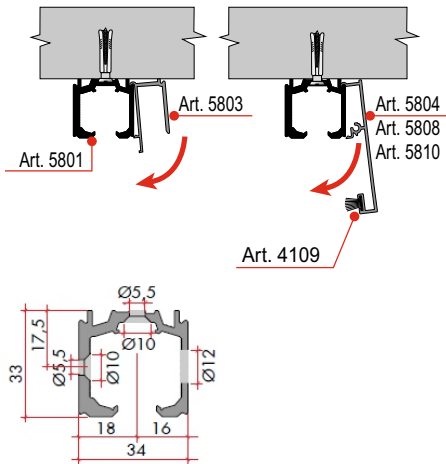

Art. 5804 Art. 5808 Art. 5810

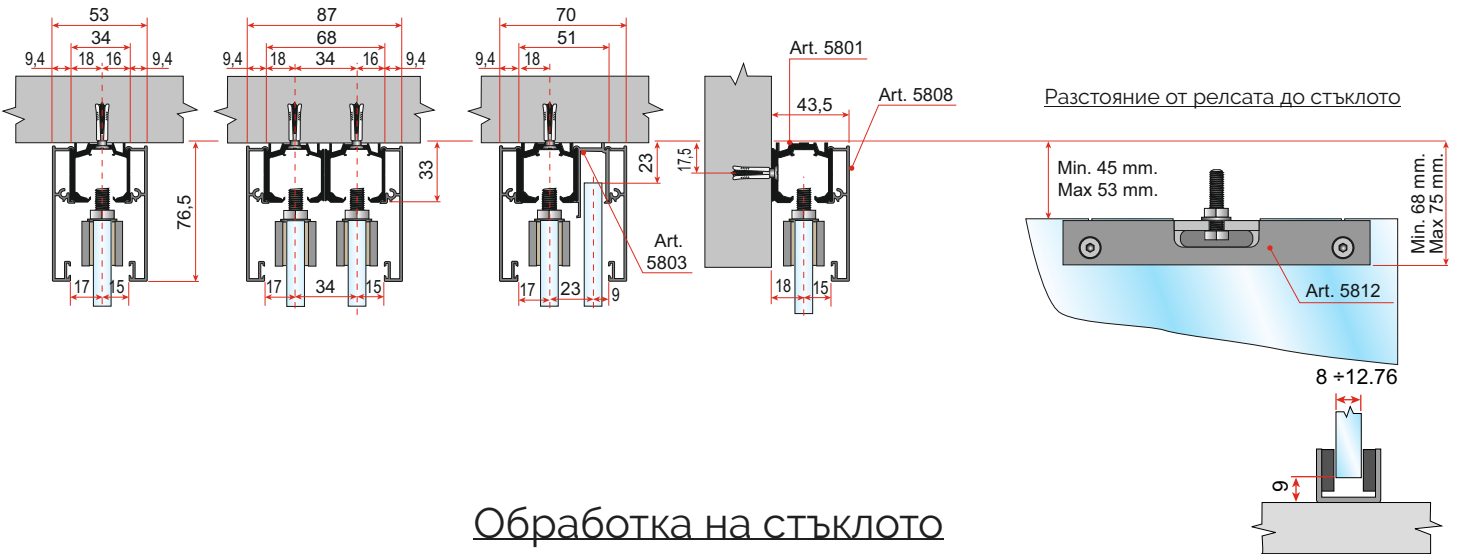

### Обработка на стъклото

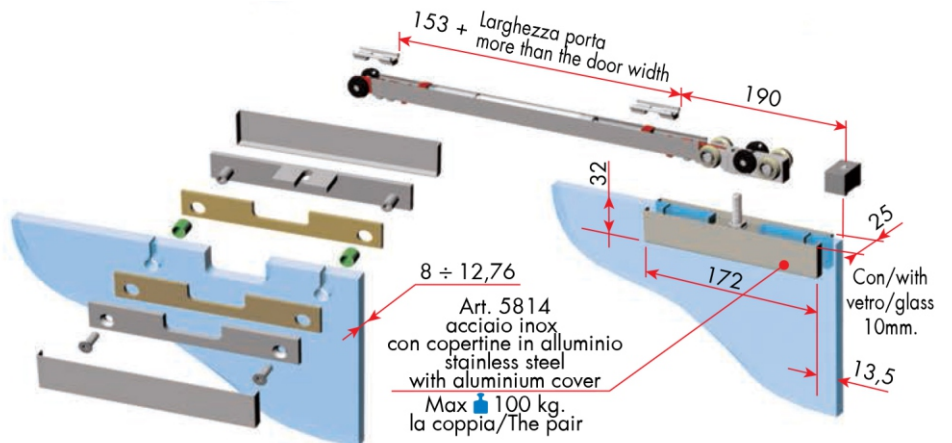
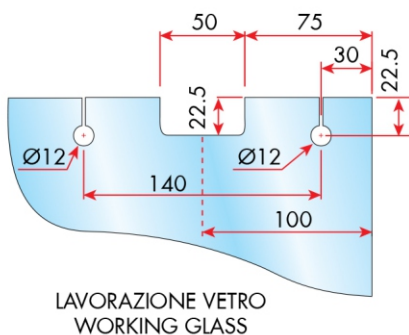

**Плъзгаща система ESBERG 2+1 с плавно отваряне и затваряне за интериорни стъклени врати за 2 врати (и фикс), телескопично синхронно, до 100 кг. на крило**



Цена за комплект за 2 плъзгащи стъклени врати и фикс, монтаж в отвор 3 метра, ширина на вратата до 1 000 мм /2x3 метра релса, 3 метра профил фикс и 6 метра капак 100 мм/  
**Цена: 1 396,00 лв с ДДС** /без стъкло и дръжки/

**/минимална ширина на вратата 600 mm./**

**Цени ка компоненти:**

Комплект Esberg 2, за плъзгане на **2 стъклени врати** с деб. 8-12,76 мм телескопично синхронно с плавно, до 100 кг на врата- **Код: 02-5787 - 819,00лв. с ДДС**

Комплект Esberg 2 за плъзгане на **2 плътни врати** с деб. до 40 мм телескопично синхронно с плавно - **Код: 02-02-5777 - 429,00лв. с ДДС** /нужно е да се направи бленда за закриване на релсата/

комплекта включва - 4 лапи за стъкло, комплект колички с амортизатор, стопери, активатори, подови водачи, корда, **НЕ включва дръжка/**

Релса за плъзгане, алуминий - **Код: 02-5801/A-6 - 57,00лв./метър**

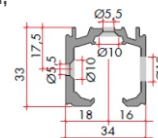

Профил за фиксирано стъкло, алуминий - **Код: 02-5803/A - 21,10 лв/метър**



Покриващ капак 75 мм, алуминий - **Код: 02-5808/A-6 - 24,70 лв/метър**

Четка 13 мм за в долния край на капака, сива - **Код: 02-4109 - 1,50 лв/метър**



Странични капачки за релса и капак 100 мм, алуминий - **Код: 02-5830/A - 19,90 лв** /използват се при монтаж на стена пред отвор, за комплект/



**Заб.:** - /релси и капаци налични на 6 метра/

## Разрези/изгледи/размери

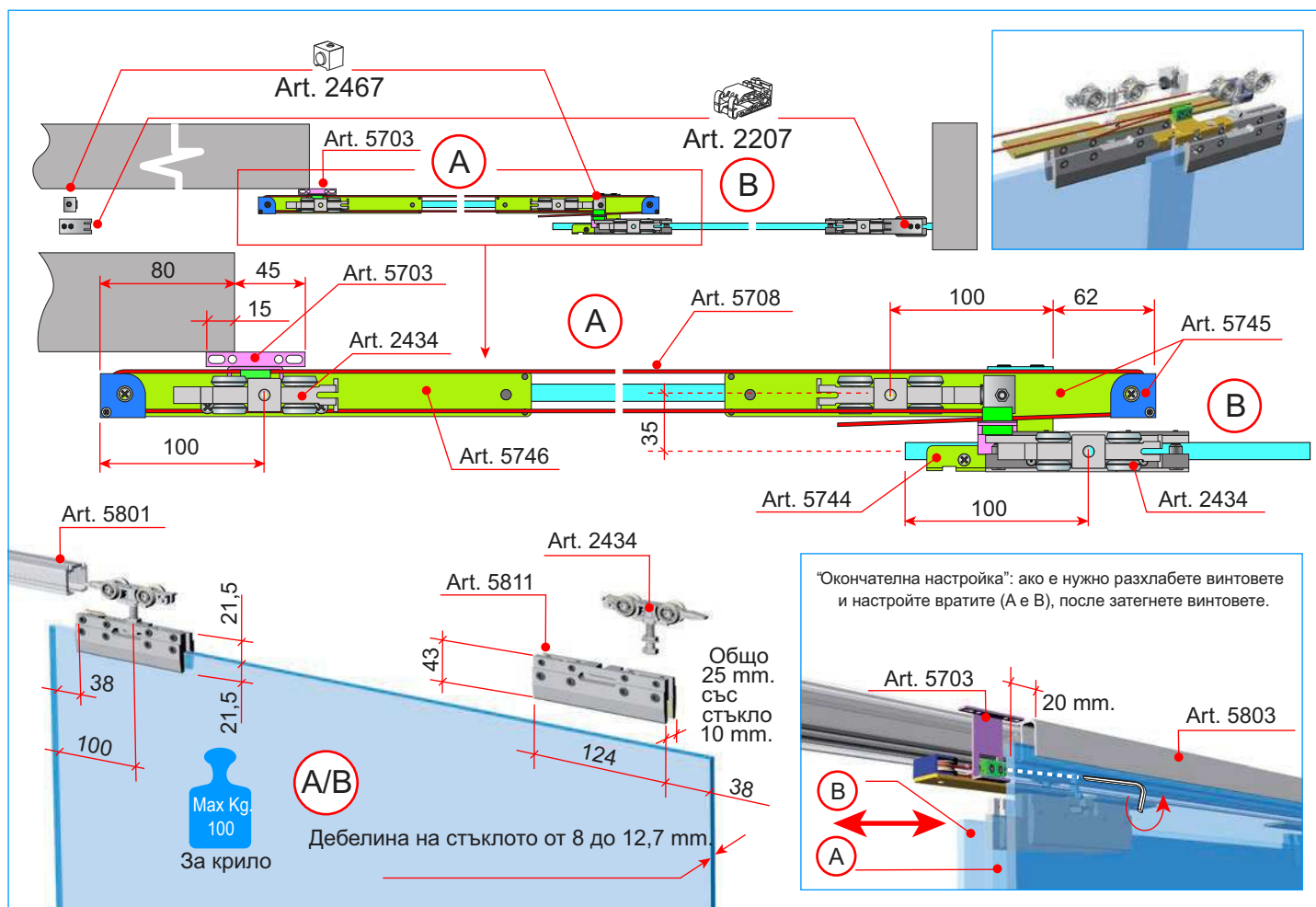
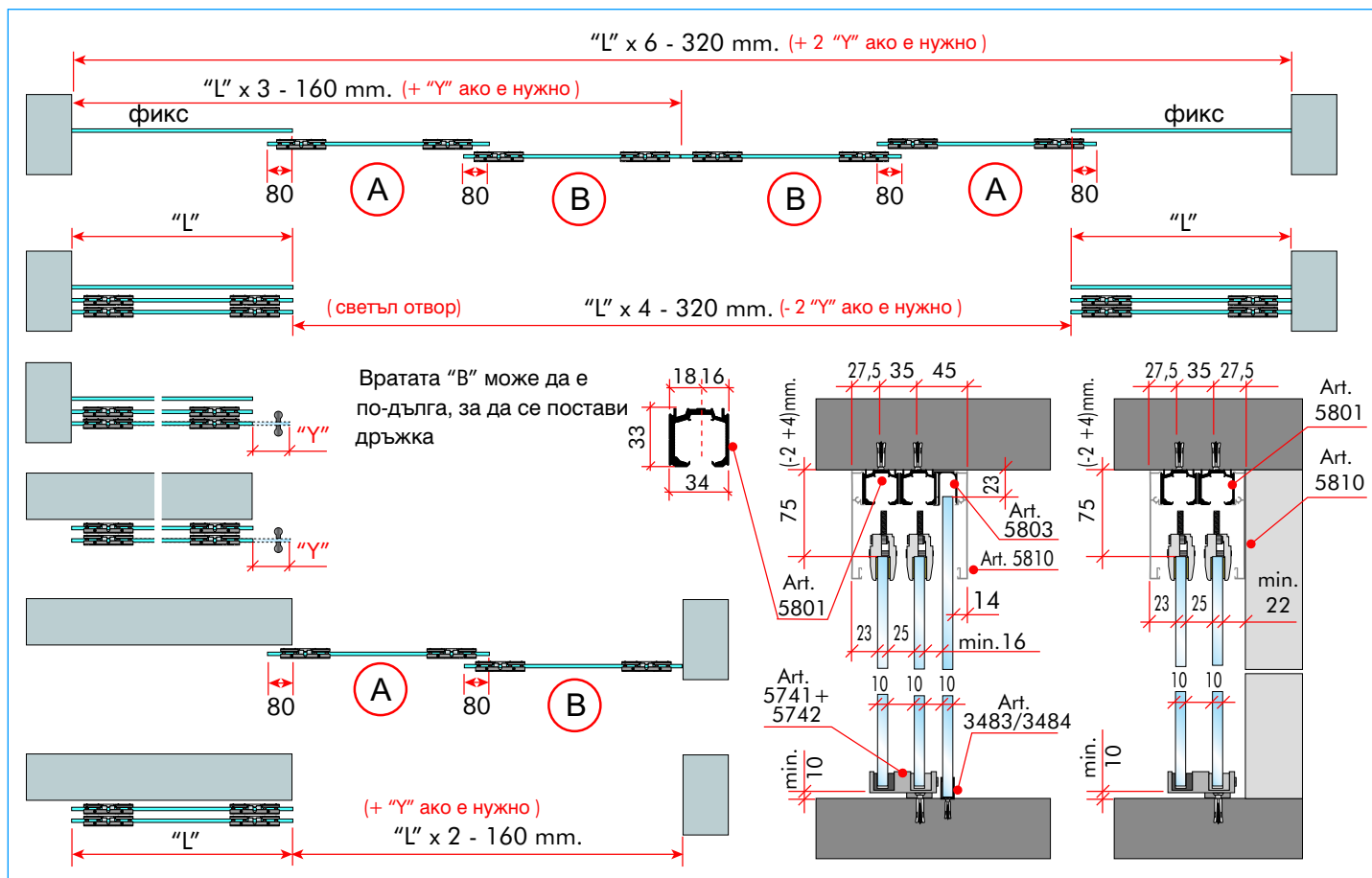

## Разрези/изгледи/размери

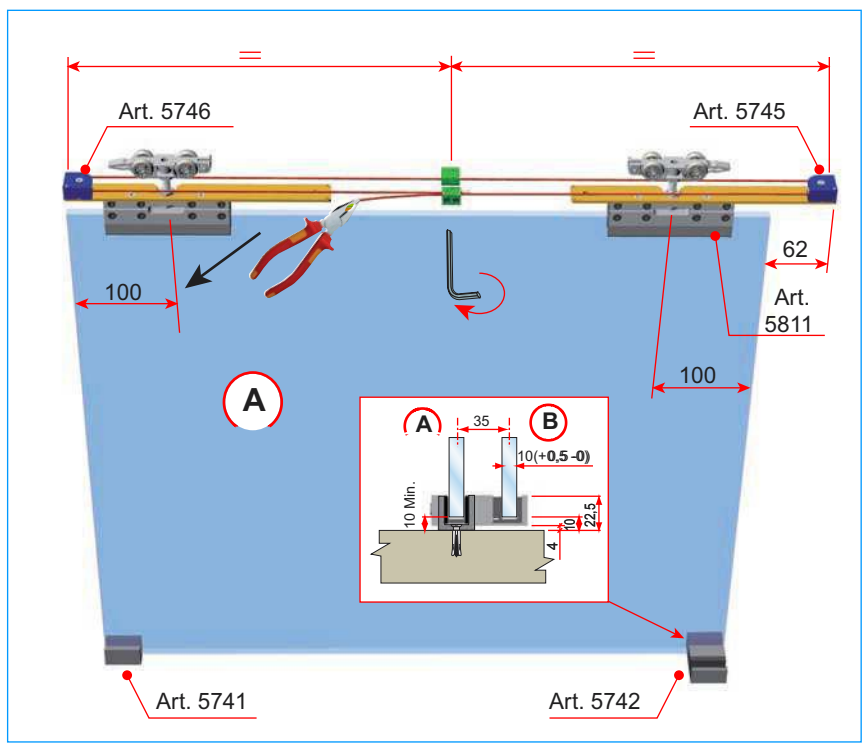
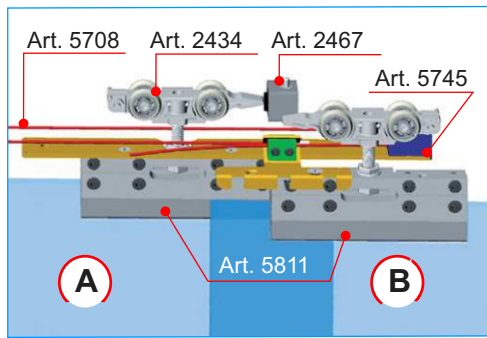
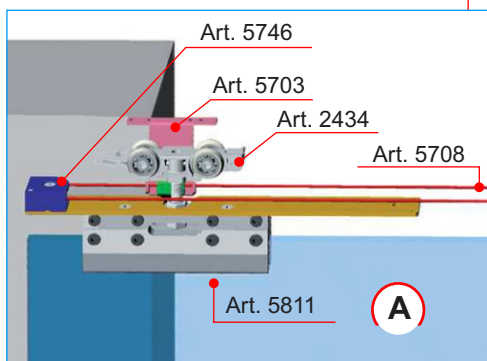
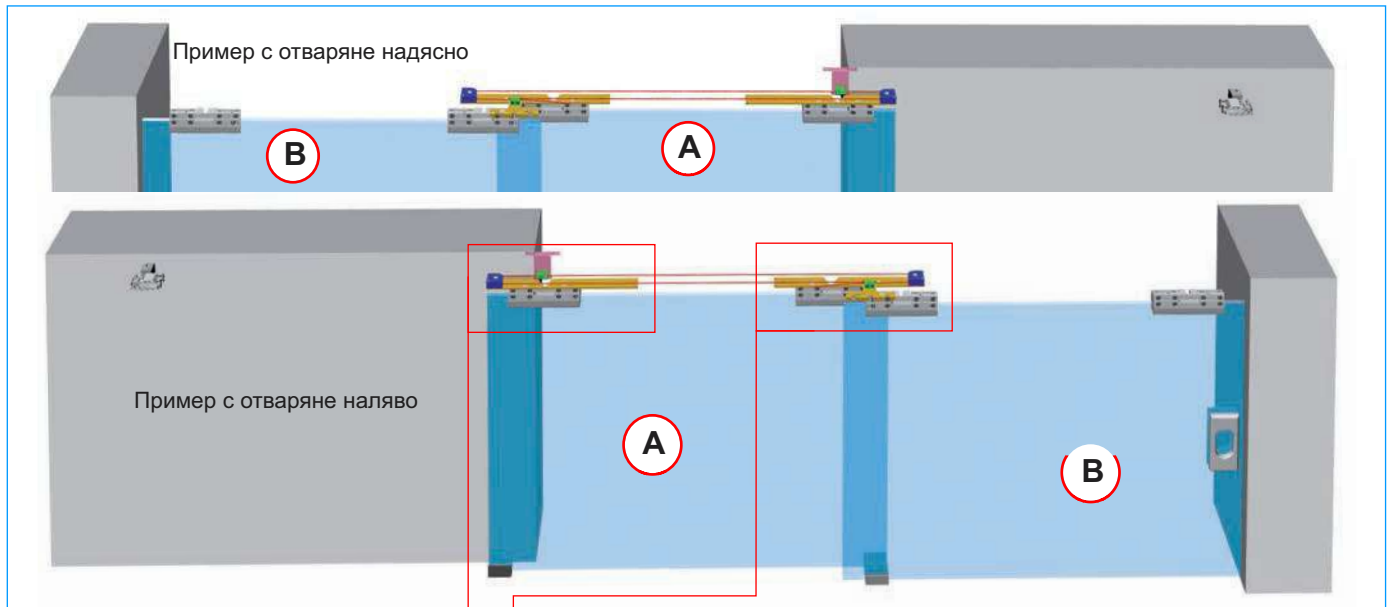
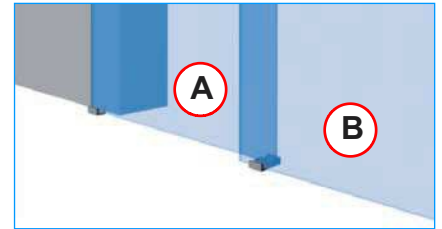
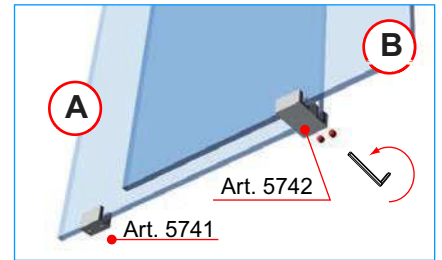
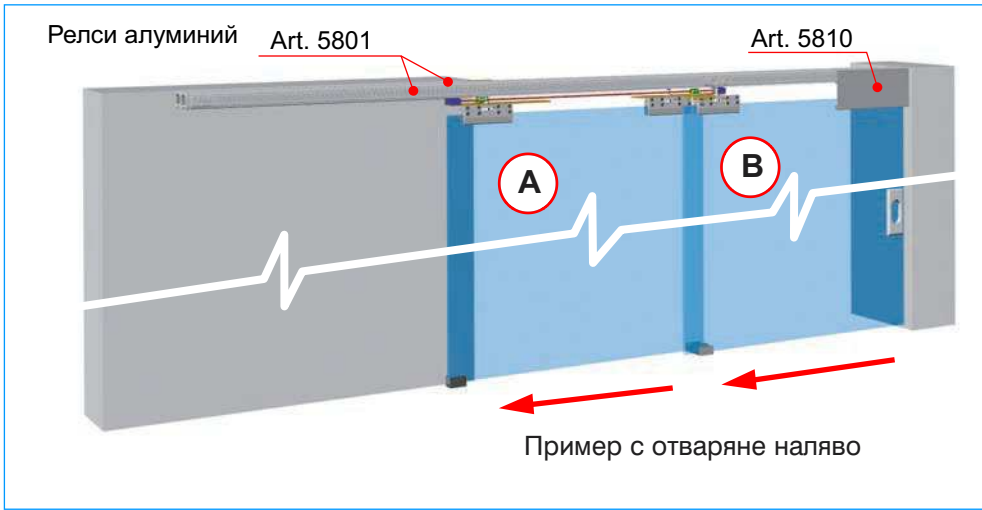



## Разреси/изгледи/размери

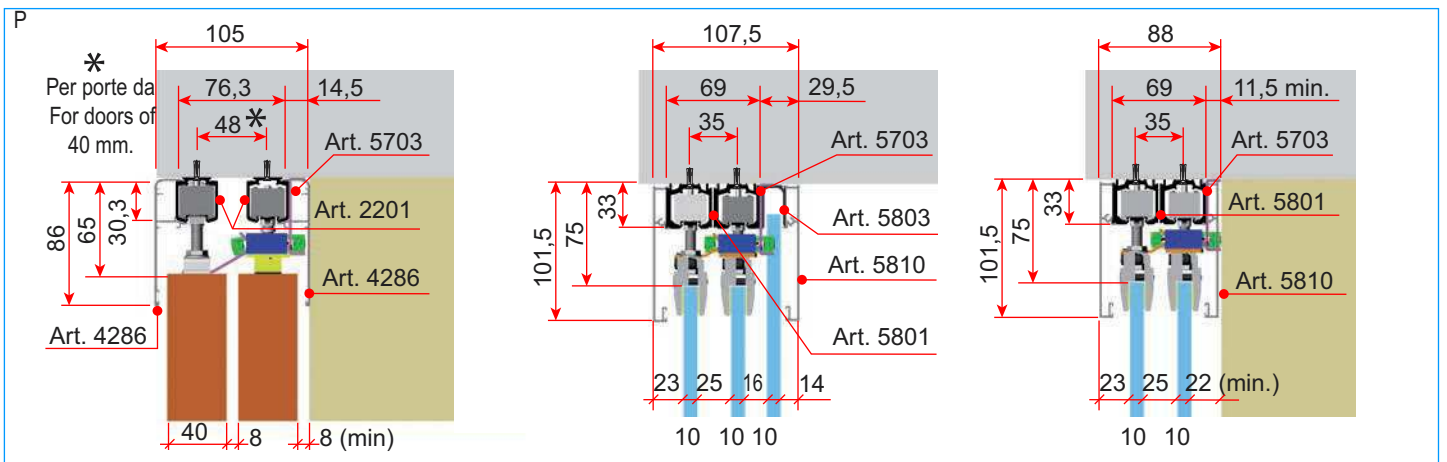

## Инструкции

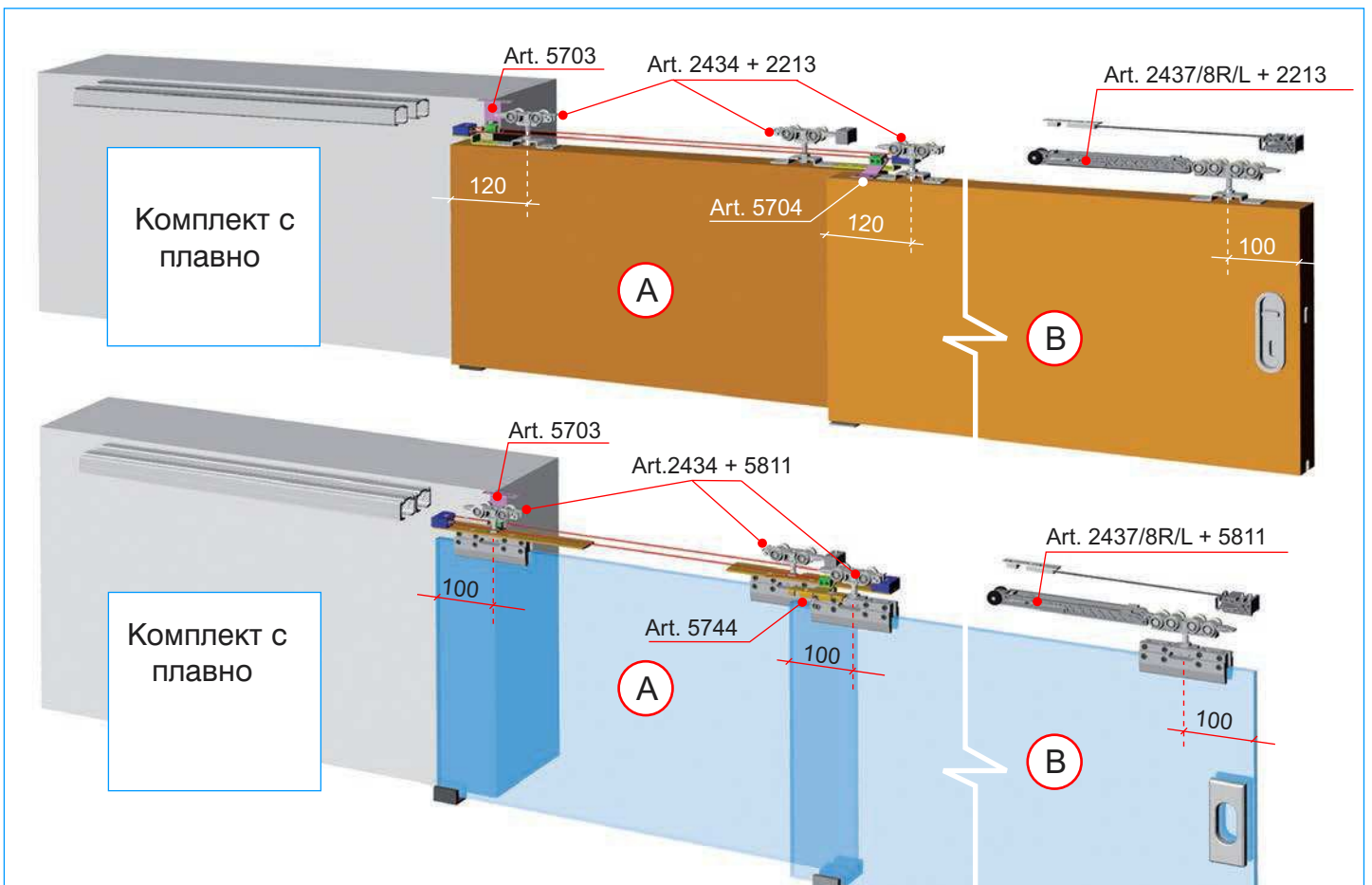
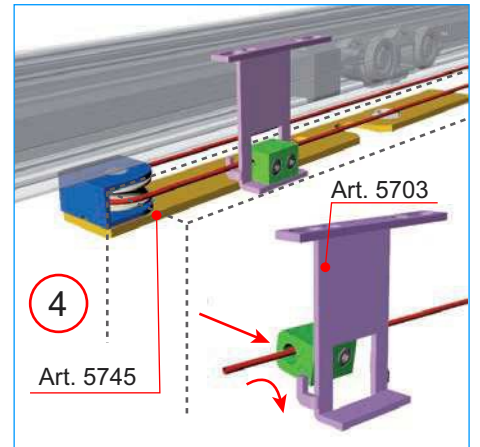
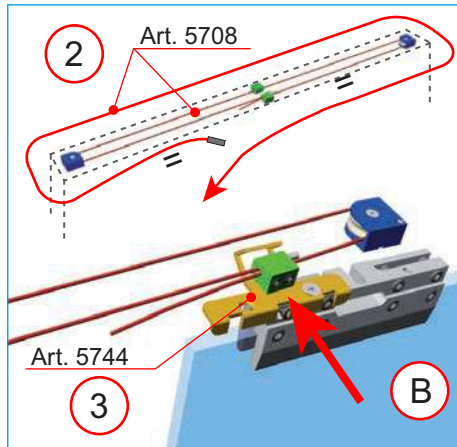
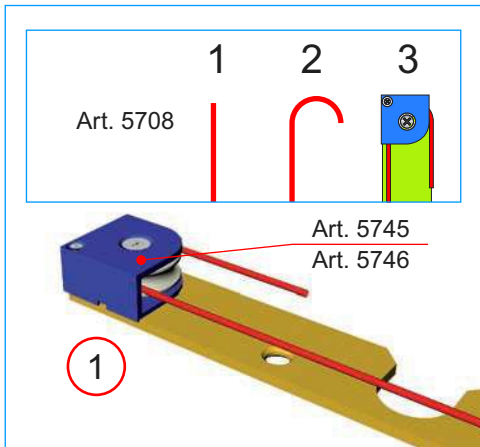

## Система за интериорно плъзгане EOS







### Технически характеристики

Макс. размер на врата (с две ролки)	1,00m x 3,00m
Дебелина на стъклото	8-10mm
Макс. тегло на вратата (с две ролки)	80Kg
Покритие	Сива елуксация - релса Сатен - ролка EOS

Комплект за плъзгане EOS, код: 22629-SL.1158.A.14 - 270.00 лв

#### Комплект за плъзгане EOS

ПРОДУКТ	КОД	ОПИСАНИЕ	КОЛ.
	1170	стопер	1
	1171	стопер със задържане	1
	1152	стоманен подов водач за стъкло	1
	619.50	стоманена дръжка МИДА	1
	1158	EOS ролка с разпробиване ф18	2

### релса

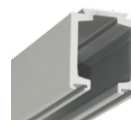

Единична релса 2 метра, код: 22942-670001-2 - 62,40 лв  
Единична релса 4 метра, код: 22942-670001 - 122,40 лв

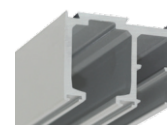

Релса с фикс 2 метра, код: 22942-670003-2 - 86,40 лв  
Релса с фикс 4 метра, код: 22942-670003 - 170,40 лв



Капачка за ед. релса, код: 22942-720033 - 10,40 лв

### брави



код: 22629-210.01  
Цена: 56,10 лв



код: 22629-227.01  
Цена: 84,00 лв



## Схеми и изрези за система EOS

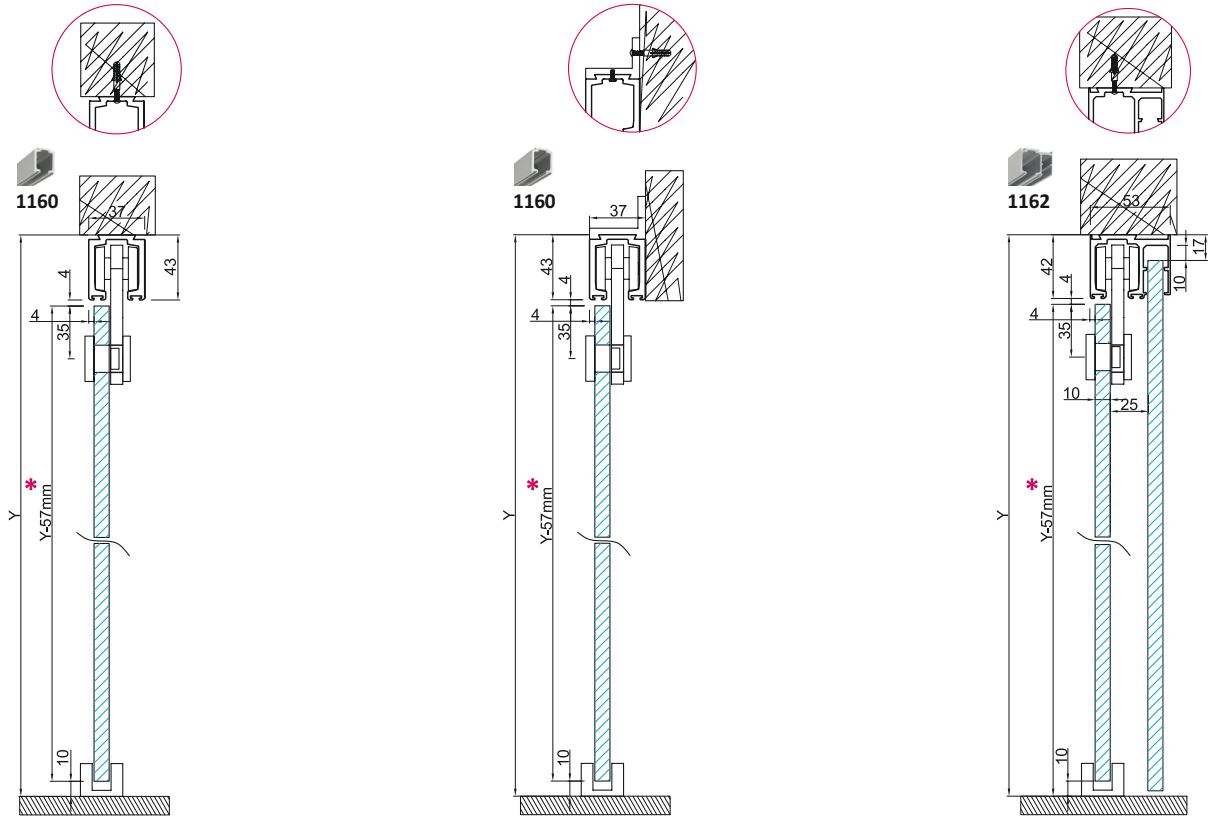

## изрязване стъкло

алуминиева релса  
алуминий 40x40  
**22942-670001**

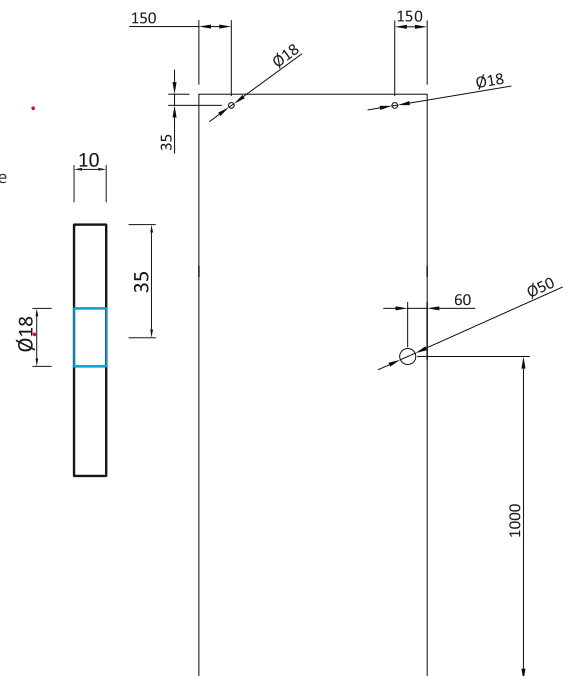
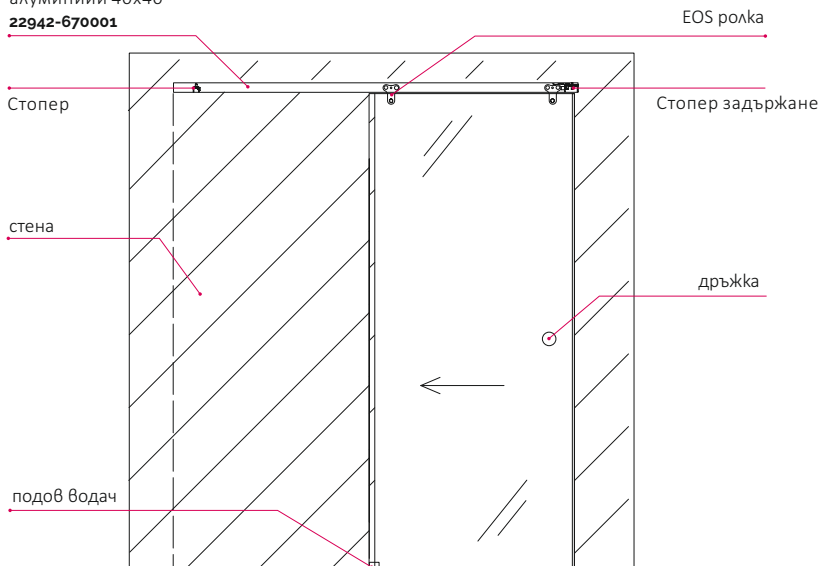

## МЕХАНИЗМИ ЗА ИНТЕРИОРНИ СГЪВАЕМИ ВРАТИ СЕРИЯ 100

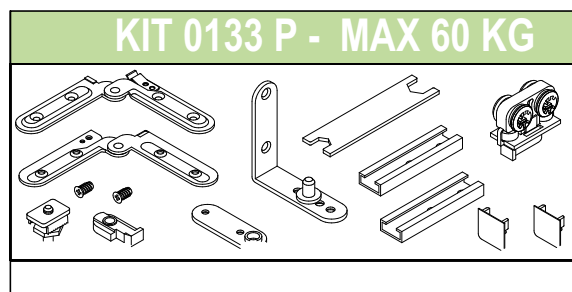

<b>0122</b>	Carrello superiore con rulli Upper truck with rollers
<b>0123</b>	Carrello superiore con cuscinetti Upper truck with roller-bearings
<b>0124</b>	Perno superiore Upper pin
<b>0125</b>	Perno inferiore Lower Pin
<b>0126</b>	Cerniera con molla per porta spessore 30 mm. Hinge with spring for door thickness 30 mm.
<b>0127</b>	Cerniera per porta spessore 30 mm. Hinge for door thickness 30 mm.
<b>0128</b>	Tappo terminale End-plug
<b>0129</b>	Cerniera con molla per porta spessore 40 mm. Hinge with spring for door thickness 40 mm.
<b>0130</b>	Cerniera senza molla per porta spessore 40 mm. Hinge for door thickness 40 mm. without spring
<b>0229</b>	Chiave di regolazione Adjusting spanner

### Legenda altri componenti

<b>0120</b>		Profilo alluminio superiore Upper aluminium profile
-------------	---	--

Комплект за 1 врата хармоника деб. 40 мм.  
код: **742-0133P - 42,00 лв.**

Релса за плъзгане за врата хармоника на  
2 метра, на метър, елуксация  
код: **742-0120AF - 22,00 лв./м**

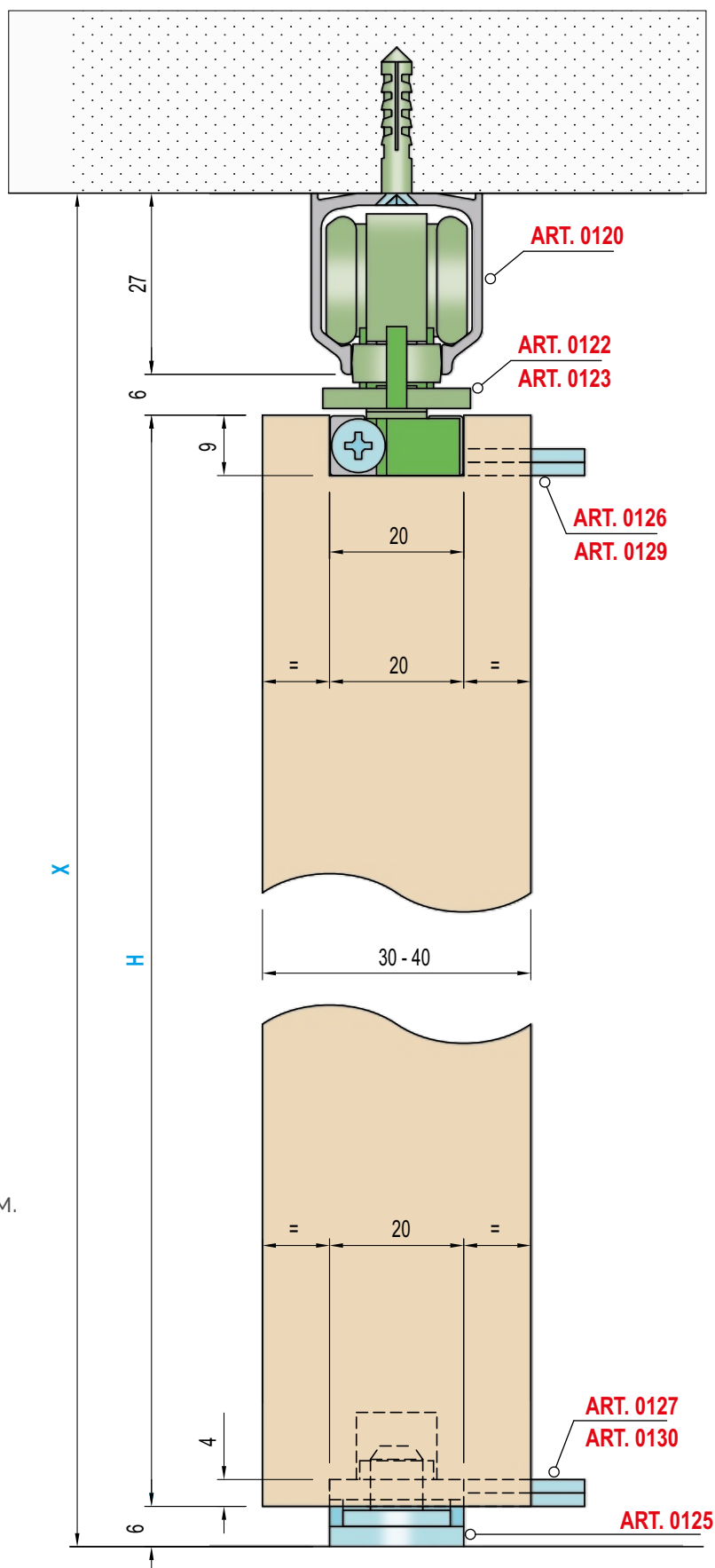

$H = X - 39$

## Сгъваема врата с 2 еднакви крила

Размерите за монтаж са същите като на врати с еднакви крила, само "К" определя позицията на алуминиевите втулки за горната количка art. 0122-0123.

### Врата с дебелина 30 mm.

**K** = 8 mm. за отваряне на 105° (прпоръчително)

**K** = 16 mm. за отваряне на 90°

### Врата с дебелина 40 mm.

**K** = 25 mm. за отваряне на 105° (прпоръчително)

**K** = 36 mm. за отваряне на 90°

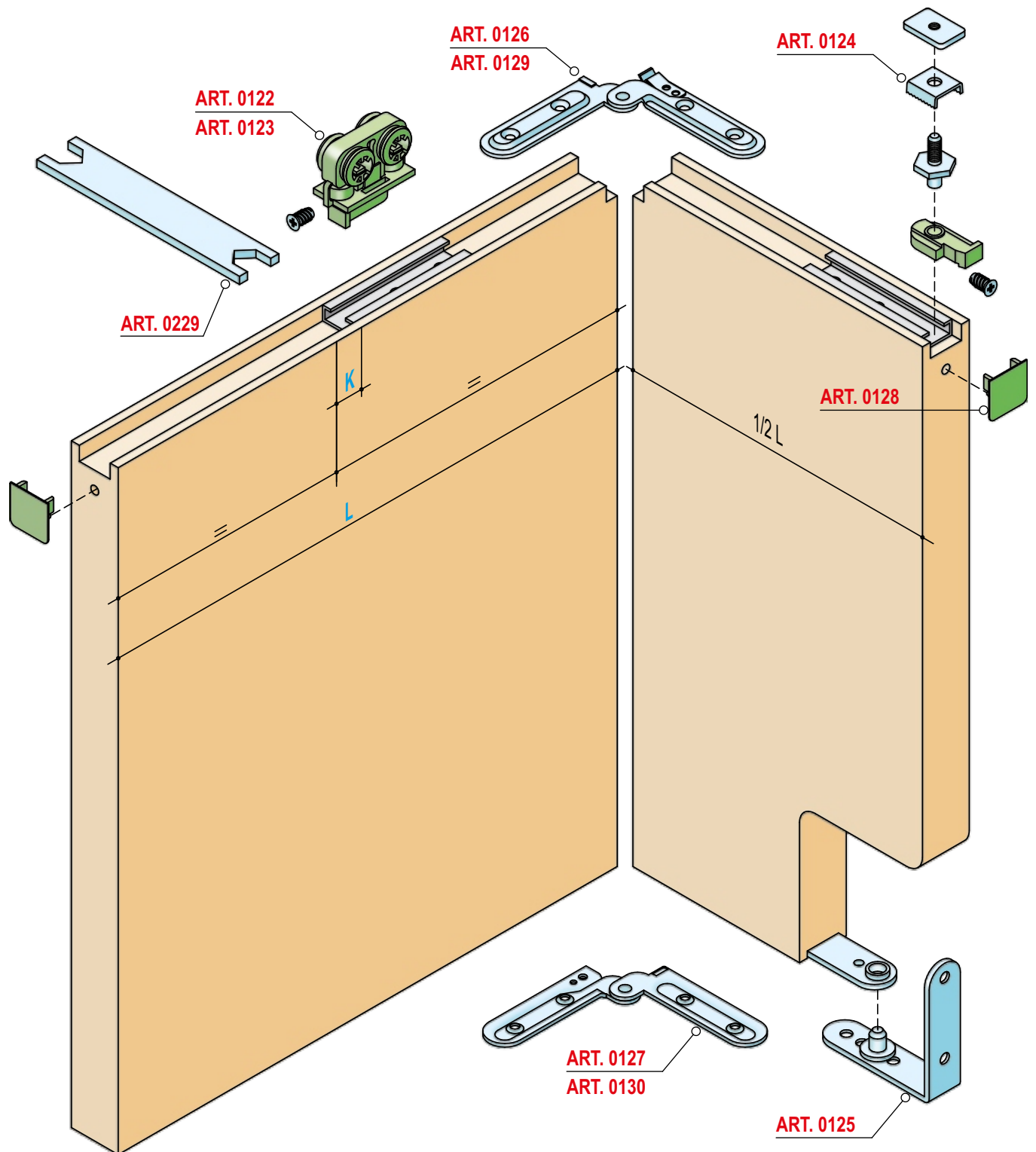

## Porta pieghevole con ante simmetriche



Схема разпробиване за 2 еднакви врати с дебелина. 30 mm.

## ИЗГЛЕД ОТПРЕД



## VISTA SUPERIORE - TOP VIEW

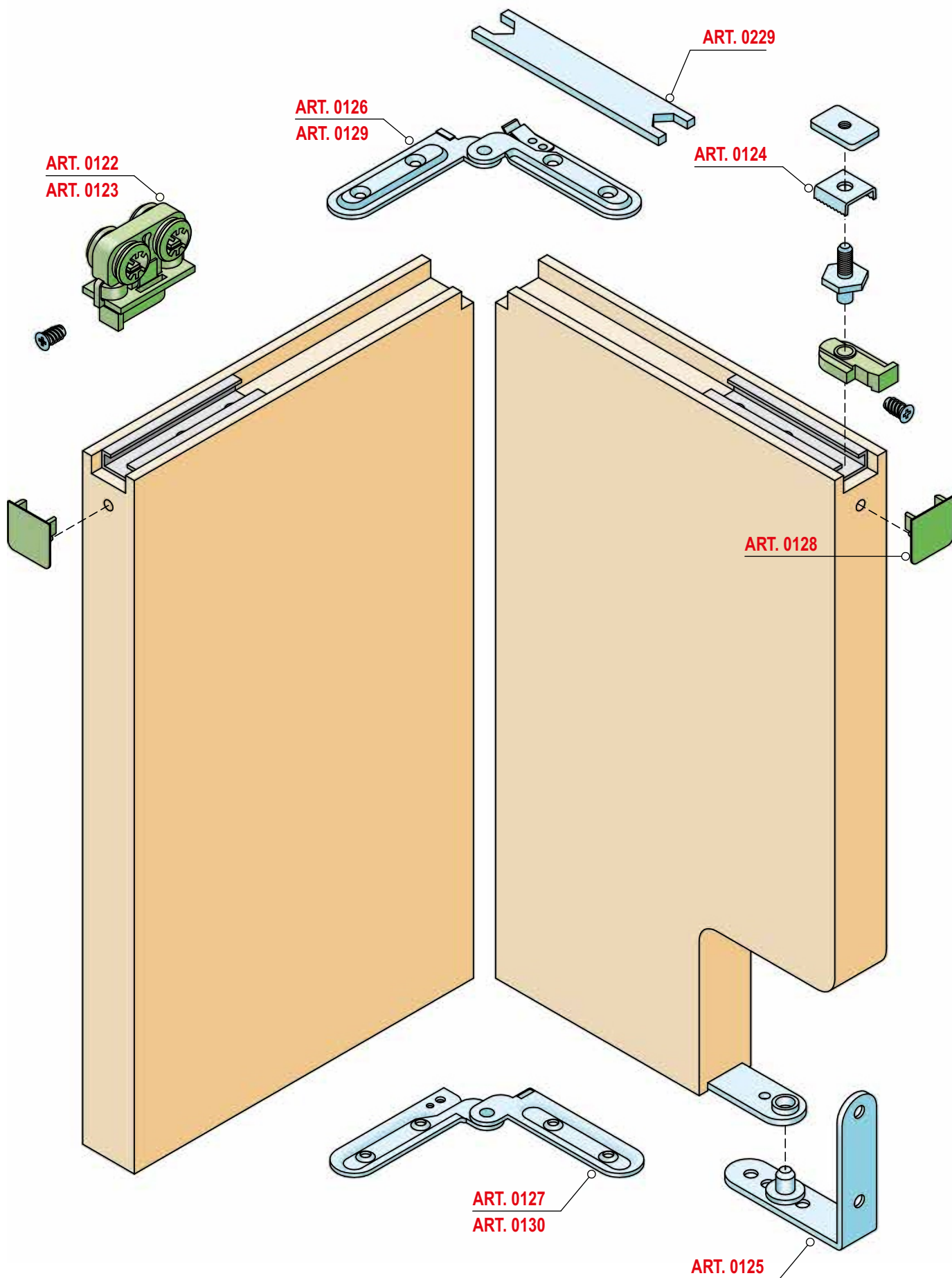
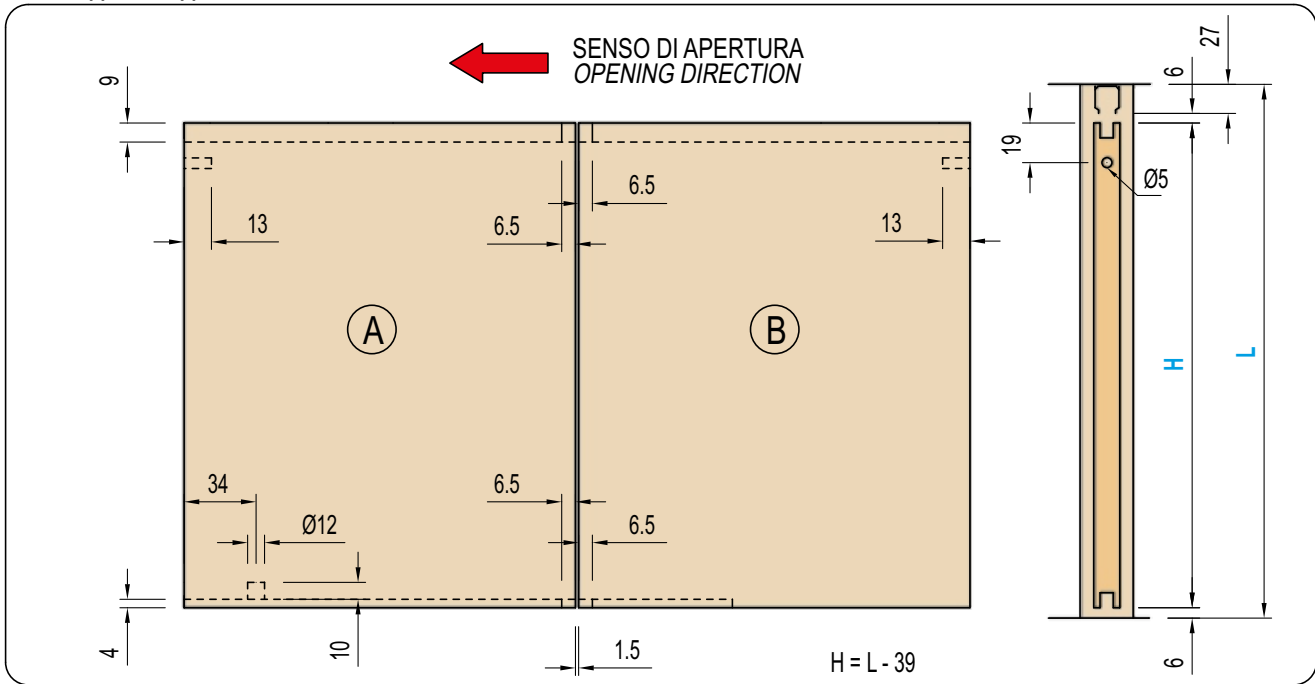
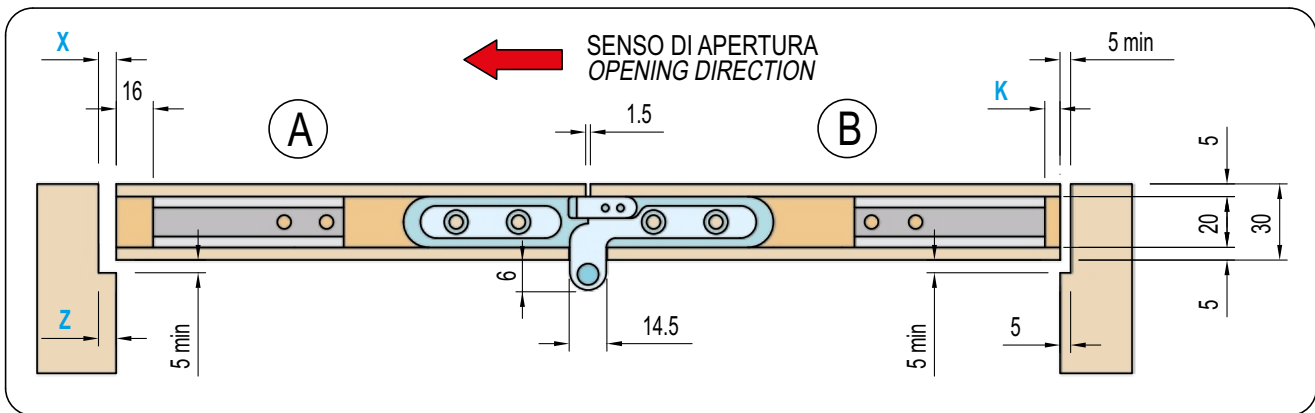

## VISTA INFERIORE - BOTTOM VIEW

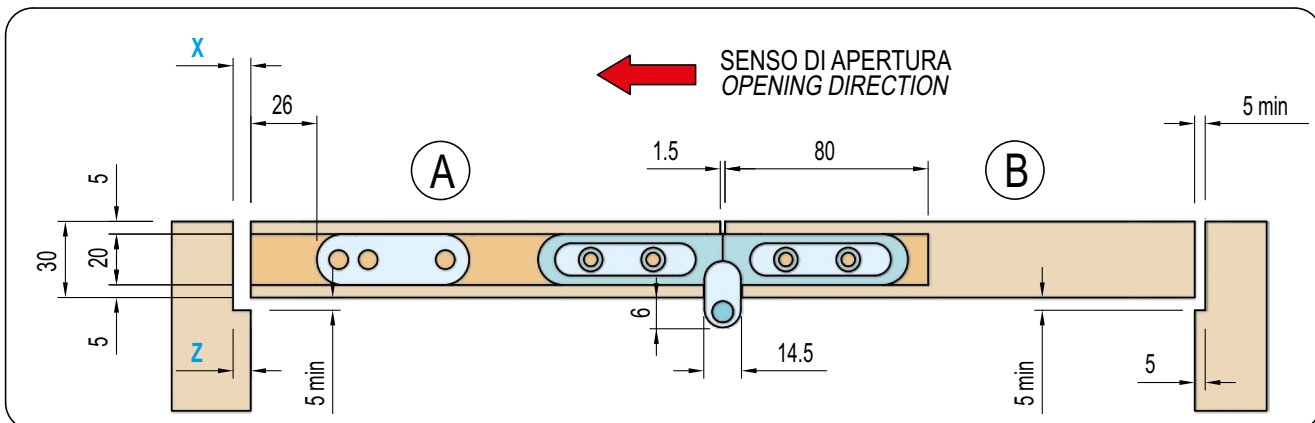

X =	6 mm. CON ART.0125 A FILO STIPITE
X =	9 mm. CON ART.0125 ESTERNO ALLO STIPITE
Z =	X X
K =	8 mm. PER APERTURA A 105° (CONSIGLIATA)
K =	16 mm. PER APERTURA A 90°



Схема разпробиване за 2 еднакви врати с дебелина 40 мм.

## ИЗГЛЕД ОТПРЕД

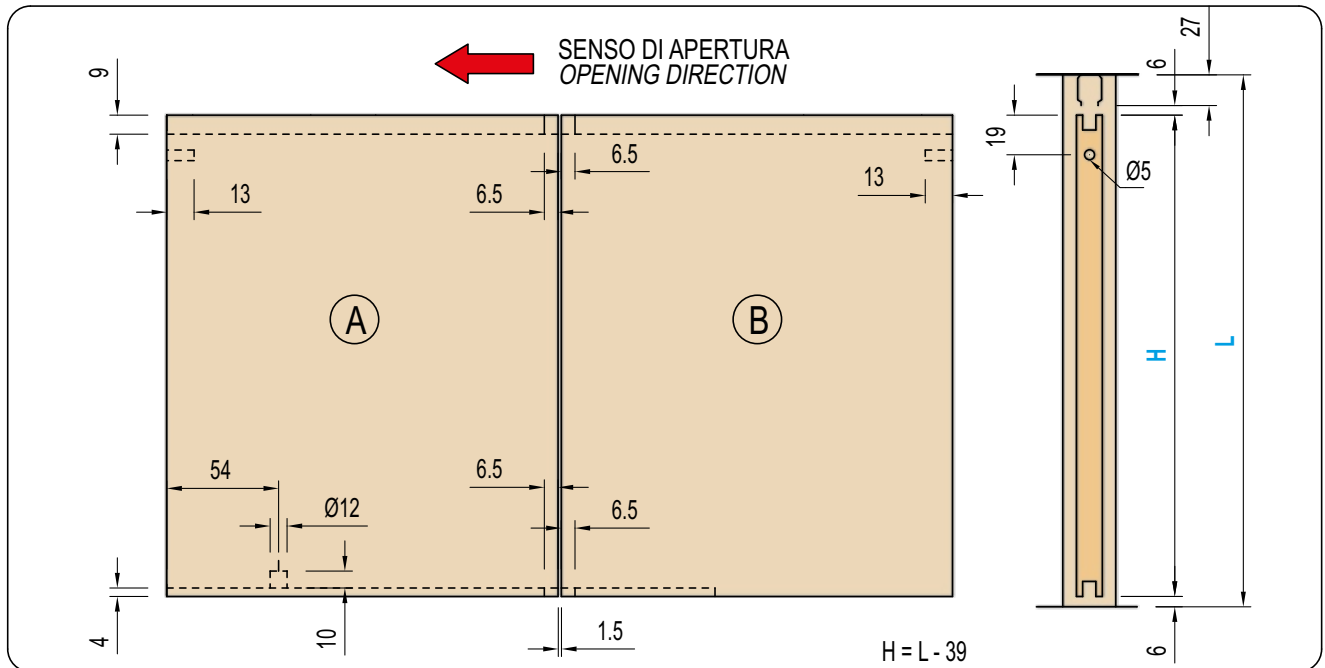

## VISTA SUPERIORE - TOP VIEW

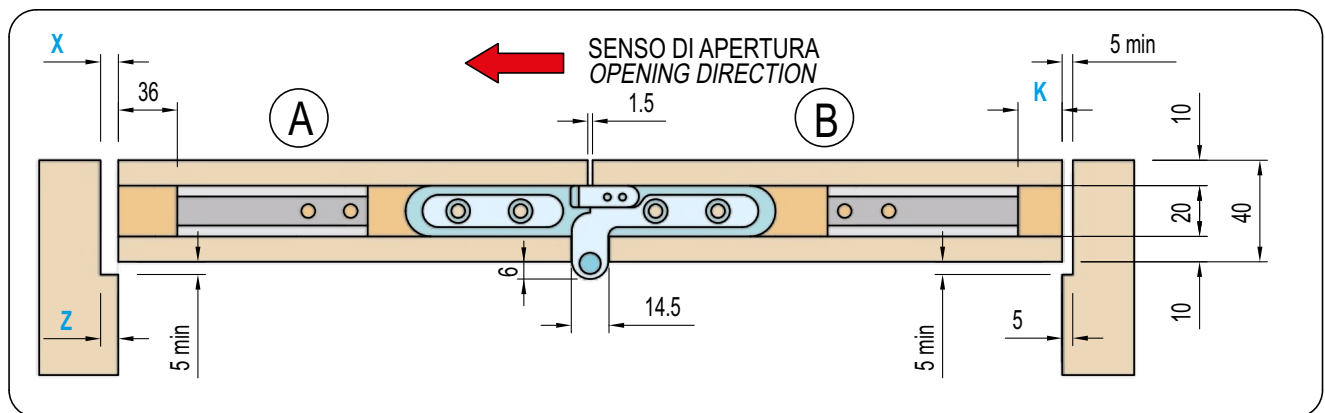

## VISTA INFERIORE - BOTTOM VIEW

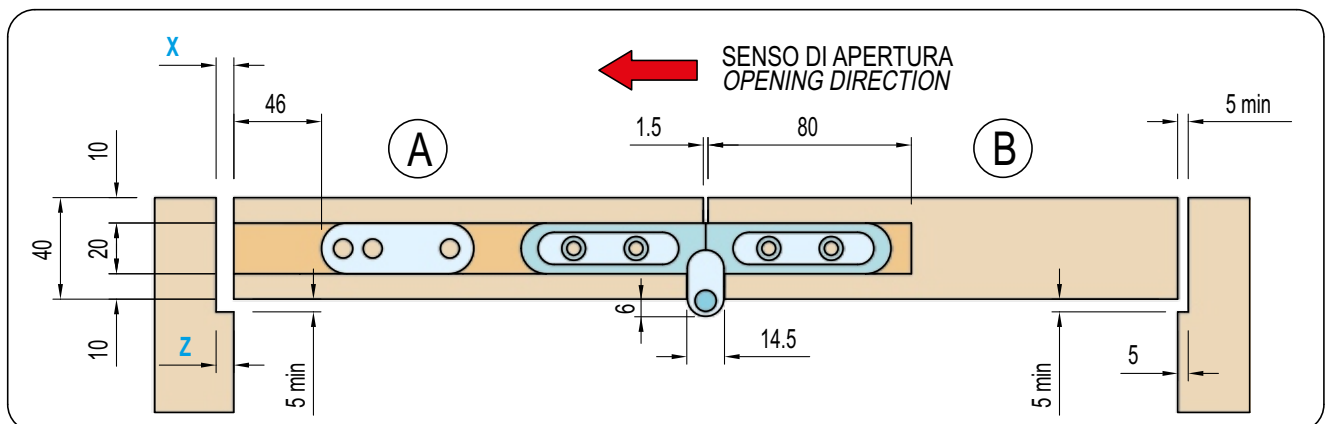

X =	6 mm. CON ART.0125 A FILO STIPITE
X =	9 mm. CON ART.0125 ESTERNO ALLO STIPITE
Z =	X X
K =	25 mm. PER APERTURA A 105° (CONSIGLIATA)
K =	36 mm. PER APERTURA A 90°

## Схема на монтаж

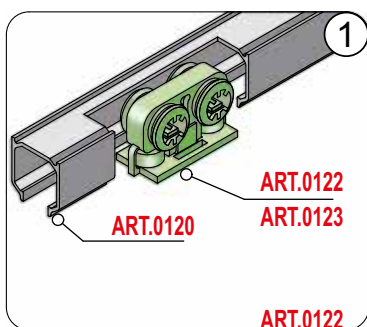

Inserire il carrello profilo di alluminio ART.0120

<b>0120</b>	Profilo alluminio superiore Upper aluminium profile
-------------	--

<b>0122</b>	Carrello superiore con rulli Upper truck with rollers
-------------	--

<b>0123</b>	Carrello superiore con cuscinetti Upper truck with roller-bearings
-------------	---

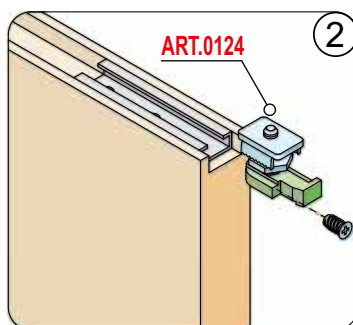

Inserire lo scivolo nel perno quindi inserirlo nell'apposita sede d'alluminio e avvitare con la "eurovite"

Insert the upper pin ART.0124 into the slide bore then insert it into the aluminium seat provided and fasten it by means of the "euro screw"

<b>0124</b>	Perno superiore Upper pin
-------------	------------------------------

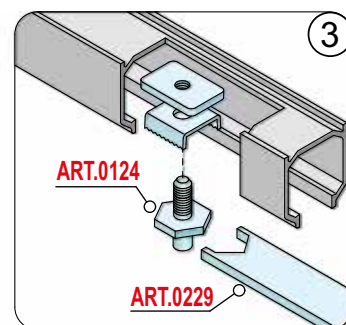

Dall'altro lato, inserire il perno superiore ART.0124 e avvitare usando la chiave di regolazione

Insert the upper pin ART.0124 into the other side and screw it by using the adjustment spanner

<b>0124</b>	Perno superiore Upper pin
-------------	------------------------------

<b>0229</b>	Chiave di bloccaggio Adjusting spanner
-------------	---

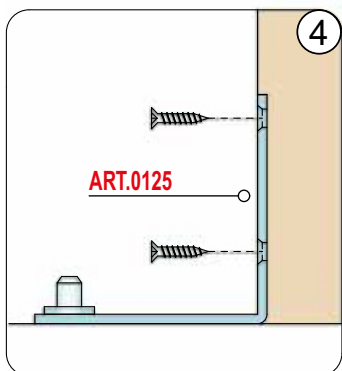

Avvitare sullo stipite la squadretta ART.0125

Screw the mounting bracket 0125 onto the doorpost

<b>0125</b>	Perno inferiore Lower Pin
-------------	------------------------------

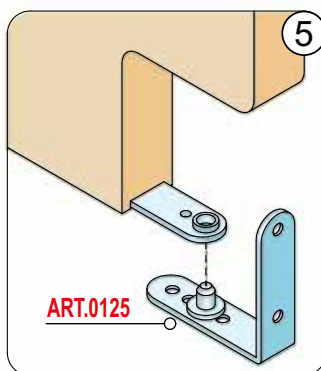

Avvitare la piastrina ovale sotto la porta, quindi inserire la porta sulla

Screw the oval plate under the door, than fit the door into the lower

<b>0125</b>	Perno inferiore Lower Pin
-------------	------------------------------

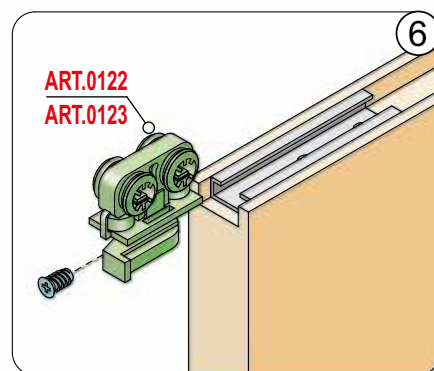

Inserire il carrello superiore ART.0122/0123 completo di scivolo nell'apposita sede di alluminio, quindi affrancarlo

<b>0122</b>	Carrello superiore con rulli Upper truck with rollers
-------------	--

<b>0123</b>	Carrello superiore con cuscinetti Upper truck with roller-bearings
-------------	---

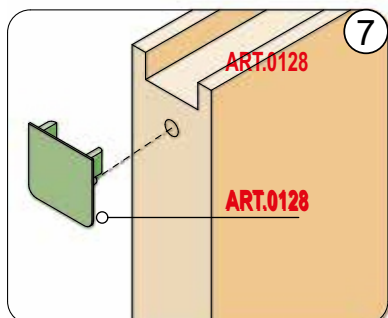

INSERIRE I TAPPI TERMINALI ART.0128

<b>0128</b>	Tappo terminale End-plug
-------------	-----------------------------